



MILITARY FAN PRODUCT FAMILY

CONTENTS

SPECIFICATIONS OF THE FANS

1

ENVIRONMENTAL SPECIFICATIONS

1

ELECTROMAGNETIC SPECIFICATIONS

2

CUSTOM DESIGN OPTIONS

2

MECHANICAL INTERFACE

2

ELECTRICAL INTERFACE

2

NOMINAL VOLTAGE RANGE

2

SPEED SIGNAL

2

INPUT SIGNAL

2

FAN PERFORMANCE CURVES

3

DC FANS

4

MERCURY38

4

MARS47

5

VENUS72

6

VENUS75

7

VENUS75

8

NEPTUNE78

9

NEPTUNE96

10

URANUS110

11

JUPITER150

12

JUPITER150

13

AC FANS

14

JUPITER150

14

JUPITER150

15

SPECIFICATIONS OF THE FANS

- The fans are designed to meet the required military standards (MIL-STD-810, MIL-STD-461, MIL-B-28873) and harsh ambient conditions.
- The fans are designed in accordance with ISO 1940-1 standards for the required balances.
- The case and rotor parts of the fans are made of AL6061-T6 material with five axis CNC machine and stainless steel is used as shaft material.
- Two high precision ball bearings with integrated lubricant which is suitable for operation at -54 degrees Celsius with stainless steel cover are used in the fans.
- All fans are coated in accordance with MIL-A-8625F and MIL-C-5541 standards.
- The fans receive their power from brushless DC or AC motors which are designed by ANOVA.
- The fans have high efficiency, vector-controlled drives which are designed by ANOVA.
- The fans have speed information and error signal feedback options.
- Performance tests of the fans are carried out within ANOVA in accordance with AMCA-210 standard.

ENVIRONMENTAL SPECIFICATIONS

These fan can be designed to meet the requirements of MIL-STD-704 and the following requirements of MIL-STD-810G-CHG-1;

Op. Temperature: Method 502.6 Procedure II, 501.6 Procedure II

St. Temperature: Method 502.6 Procedure I, 501.6 Procedure I

Acceleration: Method 513.7 Procedure II

Vibration: Method 514.7 Procedure I

Shock: Method 516.7 Procedure I

Salt Fog: Method 509.6

Rain: Method 506.6 Procedure I

Fungus: Method 508.7

Humidity: Method 507.6 Procedure II

Altitude: Method 500.6 Procedure II

Temp. Shock: Method 503.6 Procedure I

Fluid Contamination: Method 504.2

ELECTROMAGNETIC SPECIFICATIONS

These fan can be designed to meet the following requirements of MIL-STD-461E/F;

MIL-STD-461E/F REQUIREMENTS	TEST LIMITS
CE102, Conducted Emissions, power leads, 10 kHz to 10 MHz	Figure CE102-1
CS101, Conducted Susceptibility, power leads, 30 Hz to 150 kHz	Figure CS101-1
CS114, Conducted Susceptibility, bulk cable injection, 10 kHz to 200 MHz	Figure CS114-1
CS115, Conducted Susceptibility, bulk cable injection, impulse excitation	Figure CS115-1
CS116, Conducted Susceptibility, damped sinusoidal transients, cables and power leads, 10 kHz to 100 MHz	Figure CS116-1
RE102, Radiated Emissions, electric field, 10 kHz to 18 GHz	Figure RE102-3, Fixed Wing Internal, < 25 meters Nose to Tail
RS103, Radiated Susceptibility, Electric Field, 2 MHz to 18 GHz	Table VII, Aircraft Internal, 2 MHz-30 MHz: 20 V/m; 30 MHz-1 GHz: 20 V/m; 1 GHz-18 GHz: 60 V/m

CUSTOM DESIGN OPTIONS

ANOVA is capable of designing your FANS for different requirements and standards. We are flexible in designing custom products for your needs in short periods.

MECHANICAL INTERFACE	ELECTRICAL INTERFACE	NOMINAL VOLTAGE RANGE
Custom Flange	Flying Leads	12 VDC to 28 VDC
	Connector	
SPEED SIGNAL	INPUT SIGNAL	
FPS (Tach Output)	PWM Speed Control	
LSWD (Low Speed Warning Detection)		

FAN

PERFORMANCE CURVE

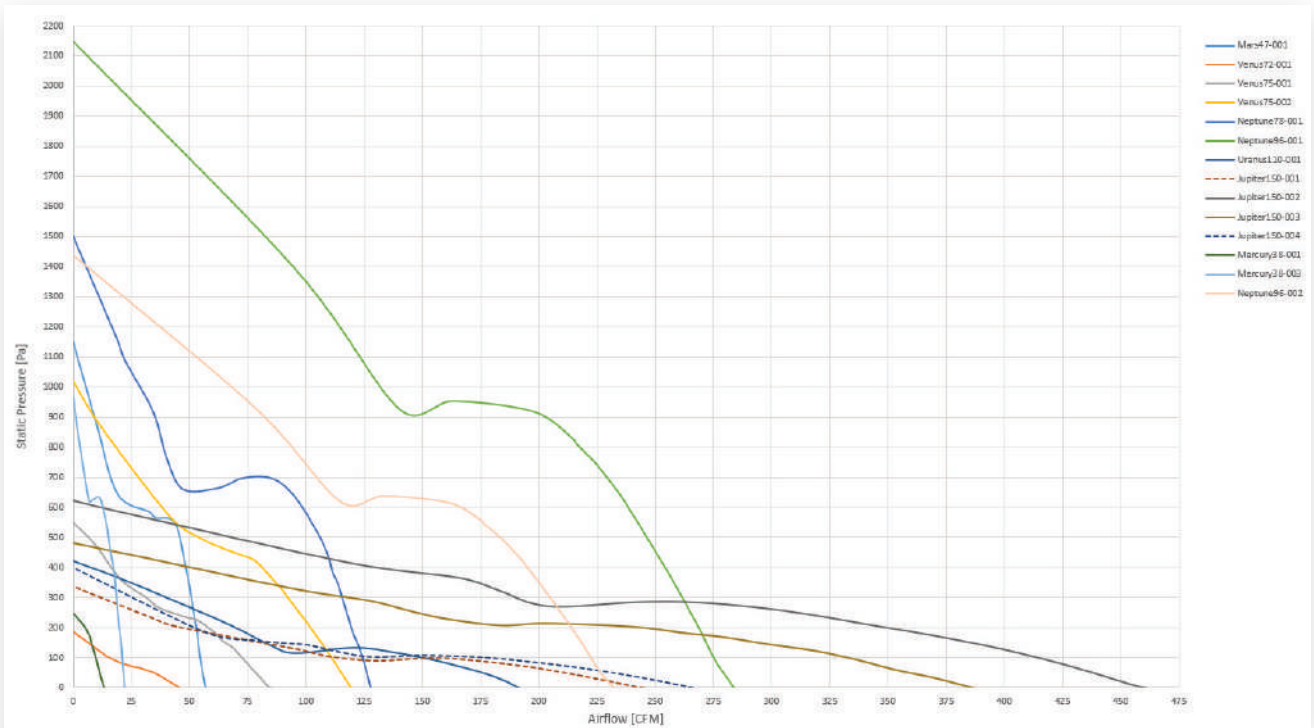

[@Air density=1,202 kg/m3]

DC FANS

MERCURY38

FAN NAME	PART NUMBER	AIRFLOW [CFM]	SPEED [RPM]	SUPPLY VOLTAGE [VDC]	NOMINAL CURRENT [AMPS]	WEIGHT [GRAMS]	SOUND PRESSURE LEVEL [dB]	PERFORMANCE CURVE	OUTLINE DRAWING	OUTPUT SIGNAL	SPEED CONTROL [PWM]
Mercury38-001	100967-001	13.4	17000	28	0.2	95 ± 10	64.3	1	Drawing 1	FPS	-
Mercury38-003	100967-003	22.2	27700	28	0.57	95 ± 10	76	2	Drawing 1	FPS, LSWD	-

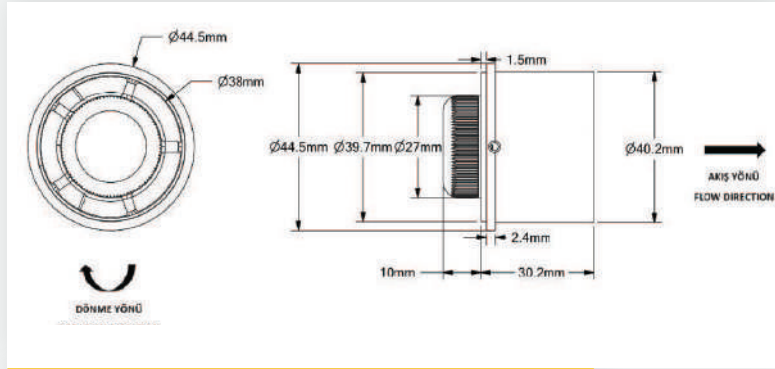

Drawing 1

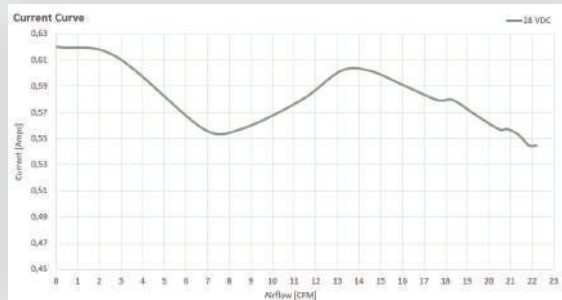
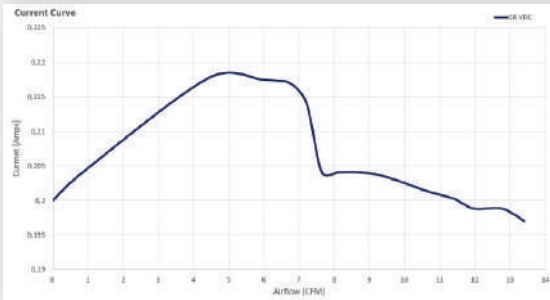
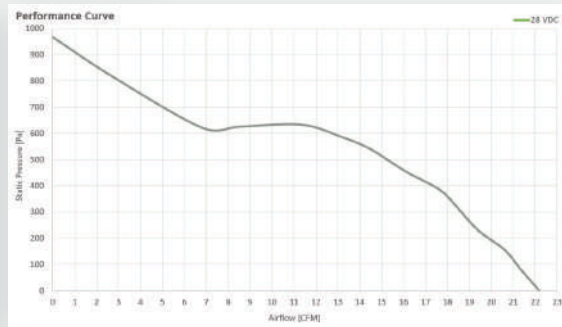
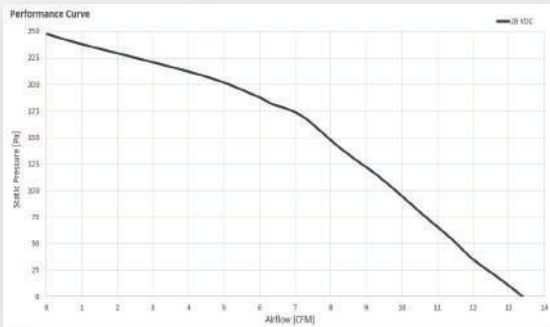

Curve 1

Curve 2

DC FANS

MARS47

FAN NAME	PART NUMBER	AIRFLOW [CFM]	SPEED [RPM]	SUPPLY VOLTAGE [VDC]	NOMINAL CURRENT [AMPS]	WEIGHT [GRAMS]	SOUND PRESSURE LEVEL [dB]	PERFORMANCE CURVE	OUTLINE DRAWING	OUTPUT SIGNAL	SPEED CONTROL [PWM]
Mars47-001	100205-001	57	21500	28	1.4	125 ± 15	73	Curve 1	Drawing 1	FPS	-

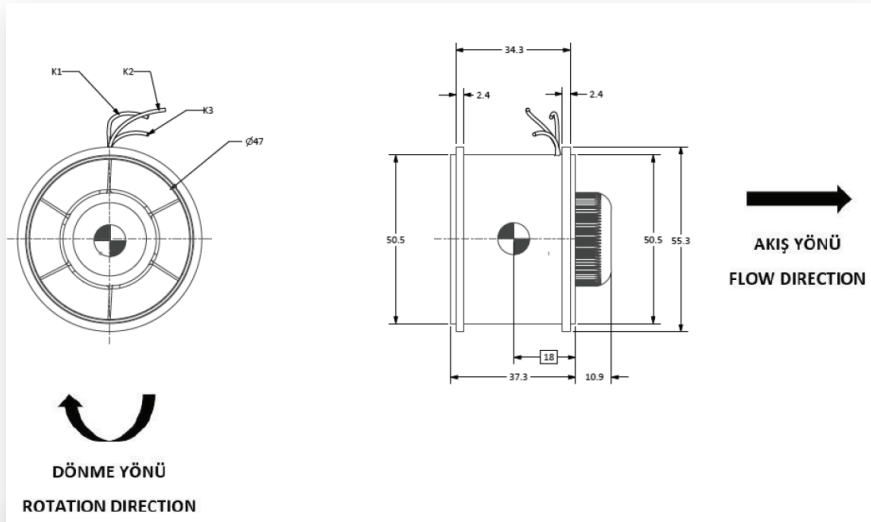

Drawing 1

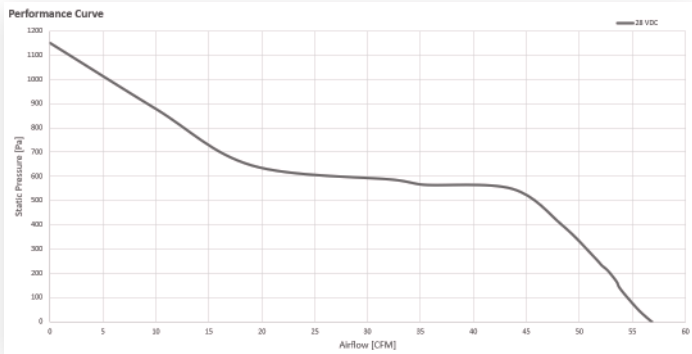

Curve 1

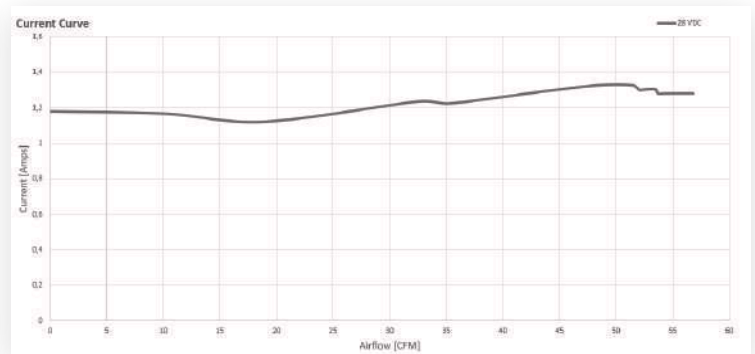

DC FANS

VENUS72

FAN NAME	PART NUMBER	AIRFLOW [CFM]	SPEED [RPM]	SUPPLY VOLTAGE [VDC]	NOMINAL CURRENT [AMPS]	WEIGHT [GRAMS]	SOUND PRESSURE LEVEL [dB]	PERFORMANCE CURVE	OUTLINE DRAWING	OUTPUT SIGNAL	SPEED CONTROL [PWM]
Venus72-001	101091-001	46.5	4700	28	0.16	225 ± 25	52	1	1	FPS	-

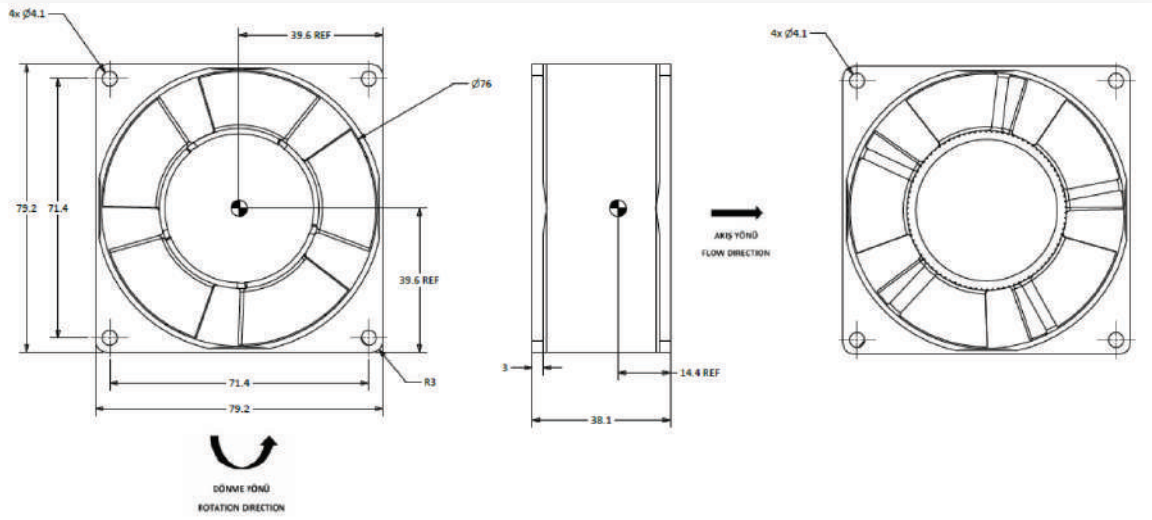

Drawing 1

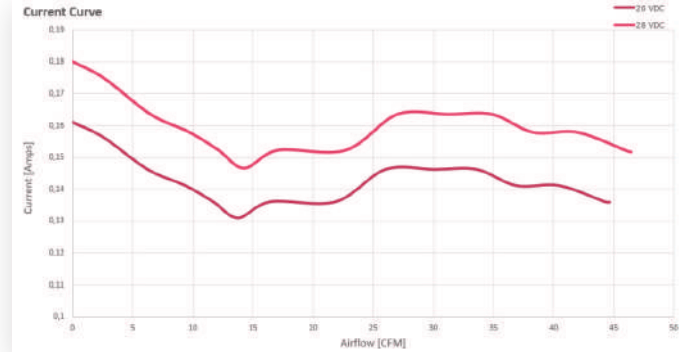
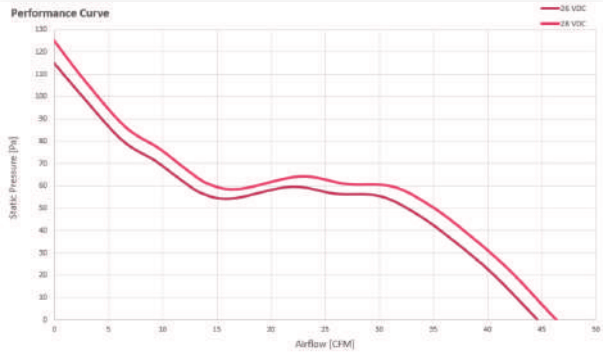

Curve 1

DC FANS

VENUS75

FAN NAME	PART NUMBER	AIRFLOW [CFM]	SPEED [RPM]	SUPPLY VOLTAGE [VDC]	NOMINAL CURRENT [AMPS]	WEIGHT [GRAMS]	SOUND PRESSURE LEVEL [dB]	PERFORMANCE CURVE	OUTLINE DRAWING	OUTPUT SIGNAL	SPEED CONTROL [PWM]
Venus75-001	100656-001	85	13500	28	0.55	155 ± 15	67	Curve 1	Drawing 1	L.S.W.D	-
Venus75-002	100656-002	119	19000	28	1.3	155 ± 15	76	Curve 2	Drawing 1	FPS	-

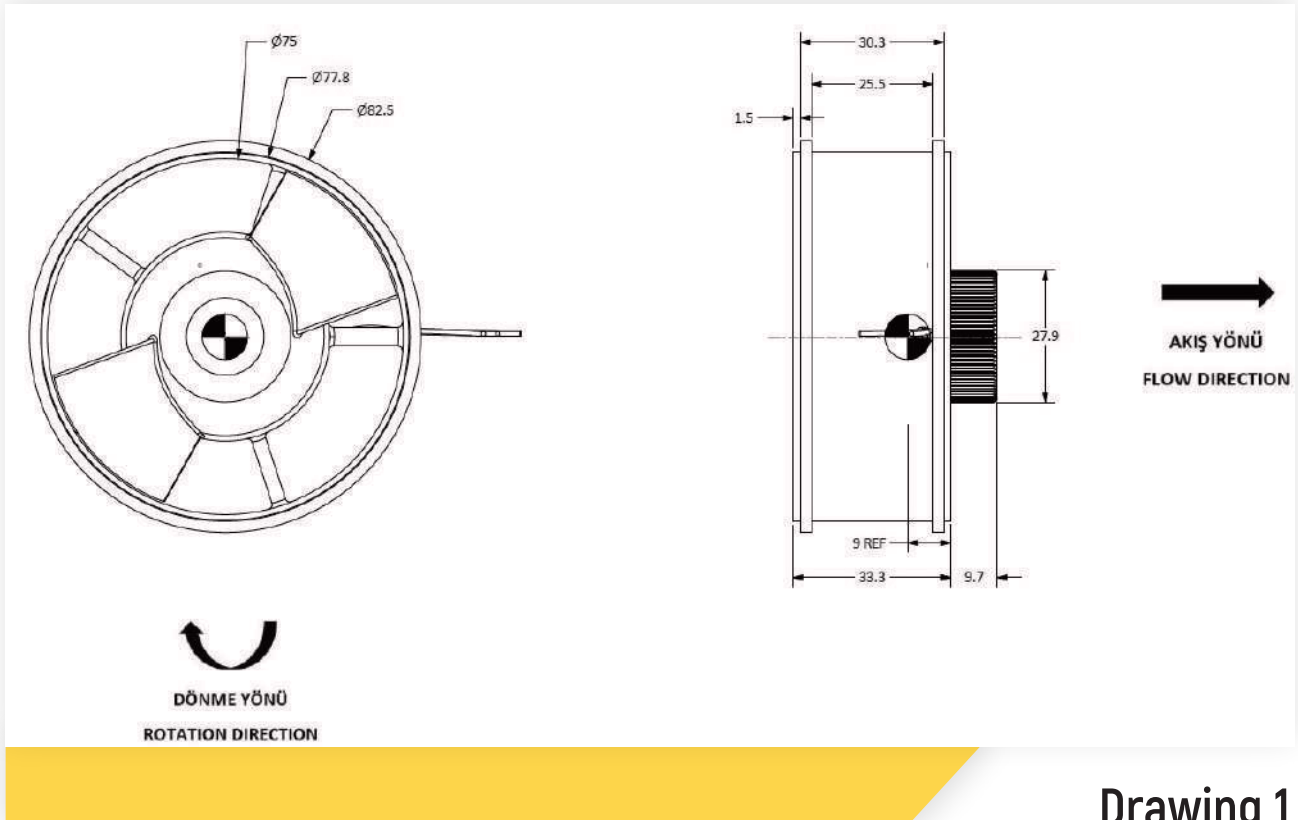

Drawing 1

DC FANS

VENUS75

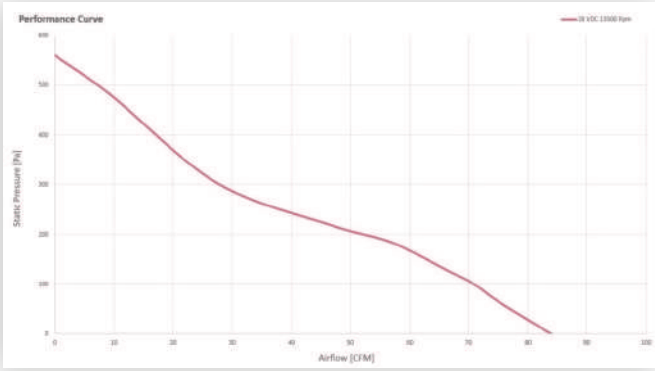

Curve 1

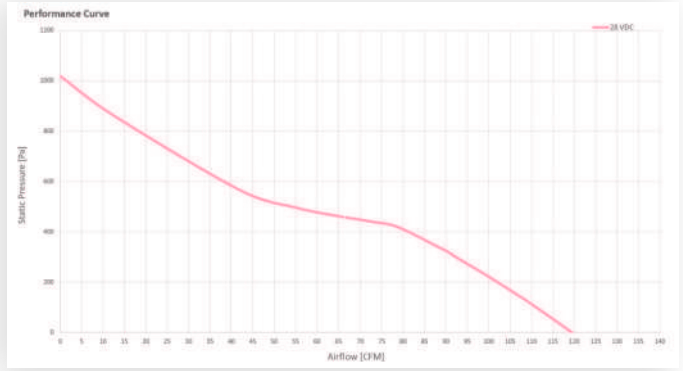

Curve 2

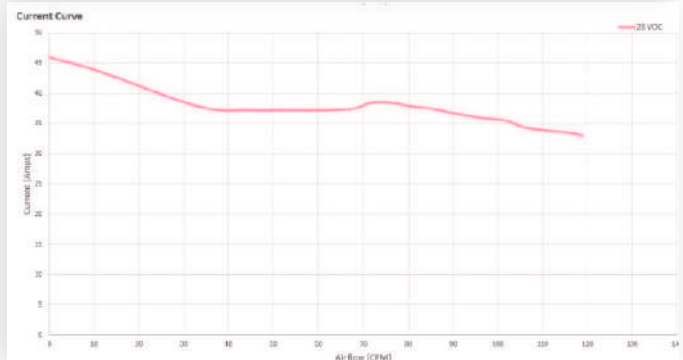
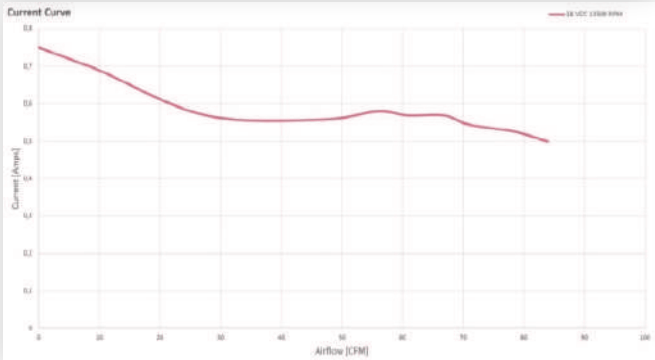

DC FANS

NEPTUNE78

FAN NAME	PART NUMBER	AIRFLOW [CFM]	SPEED [RPM]	SUPPLY VOLTAGE [VDC]	NOMINAL CURRENT [AMPS]	WEIGHT [GRAMS]	SOUND PRESSURE LEVEL [dB]	PERFORMANCE CURVE	OUTLINE DRAWING	OUTPUT SIGNAL	SPEED CONTROL [PWM]
Neptune78-001	102102-001	128	16500	28	2.75	460 ± 50	-	Curve 1	Drawing 1	FPS	-

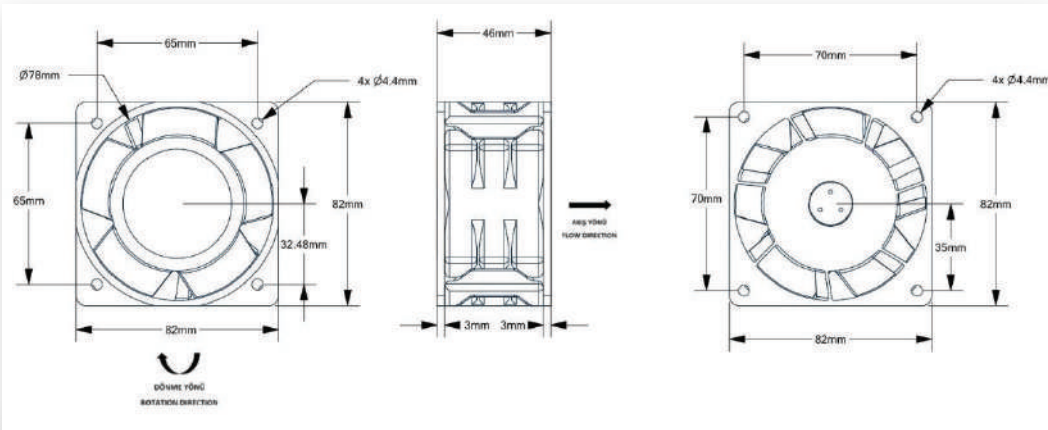

Drawing 1

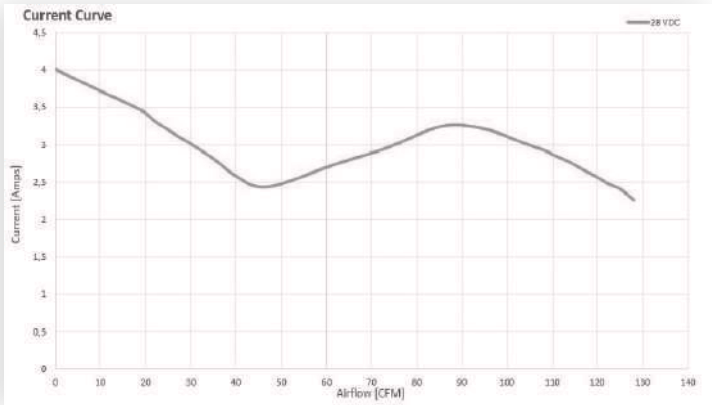
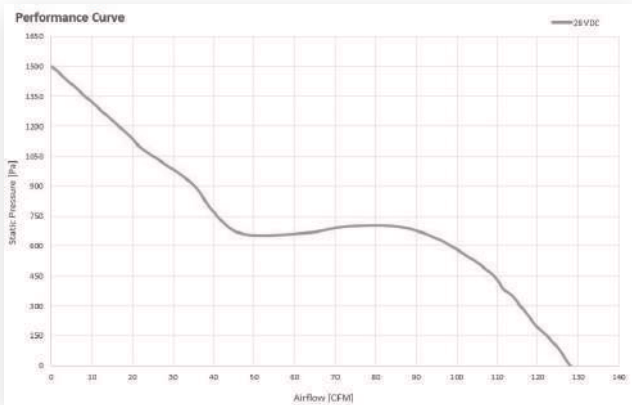

Curve 1

DC FANS

NEPTUNE96

FAN NAME	PART NUMBER	AIRFLOW [CFM]	SPEED [RPM]	SUPPLY VOLTAGE [VDC]	NOMINAL CURRENT [AMPS]	WEIGHT [GRAMS]	SOUND PRESSURE LEVEL [dB]	PERFORMANCE CURVE	OUTLINE DRAWING	OUTPUT SIGNAL	SPEED CONTROL [PWM]
Neptune96-001	100204-001	288	16500	28	6	500 ± 50	88	Curve 1	Drawing 1	FPS	-
Neptune96-002	100204-002	232	13500	28	3.5	500 ± 50	-	Curve 2	Drawing 1	FPS	-

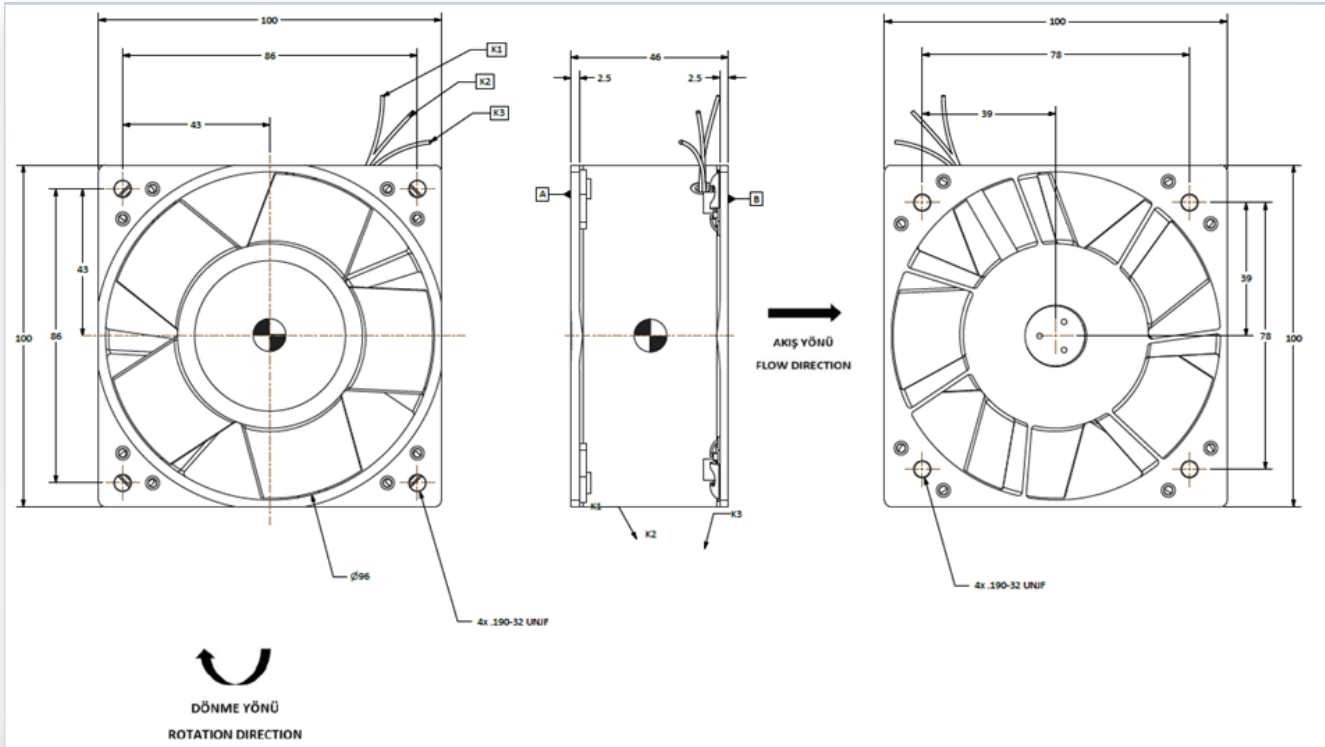

Drawing 1

DC FANS

NEPTUNE96

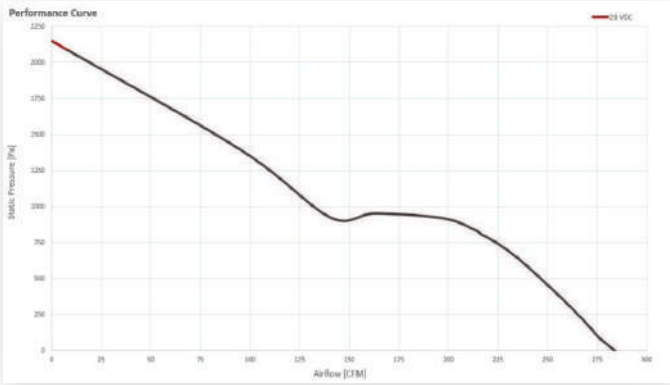

Curve 1

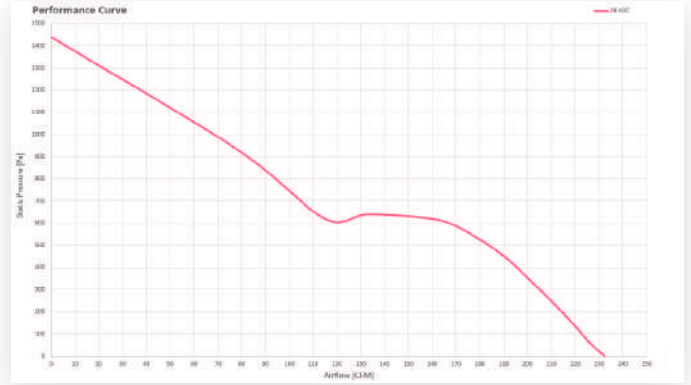
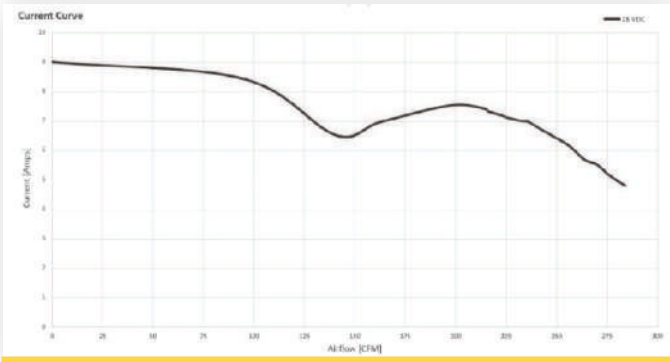

Curve 2

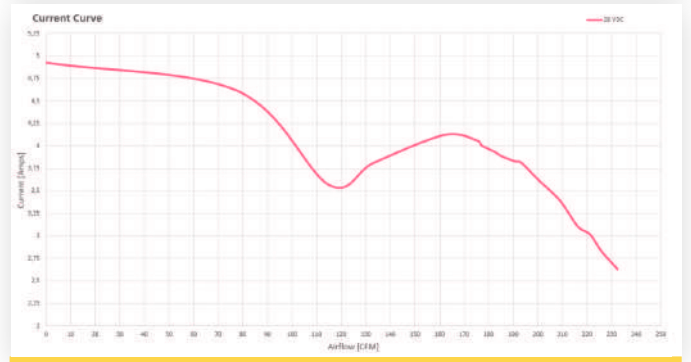

DC FANS

URANUS110

FAN NAME	PART NUMBER	AIRFLOW [CFM]	SPEED [RPM]	SUPPLY VOLTAGE [VDC]	NOMINAL CURRENT [AMPS]	WEIGHT [GRAMS]	SOUND PRESSURE LEVEL [dB]	PERFORMANCE CURVE	OUTLINE DRAWING	OUTPUT SIGNAL	SPEED CONTROL [PWM]
Uranus110-001	100605-001	192	5350	28	0.8	420 ± 20	68	Curve 1	Drawing 1	FPS	-

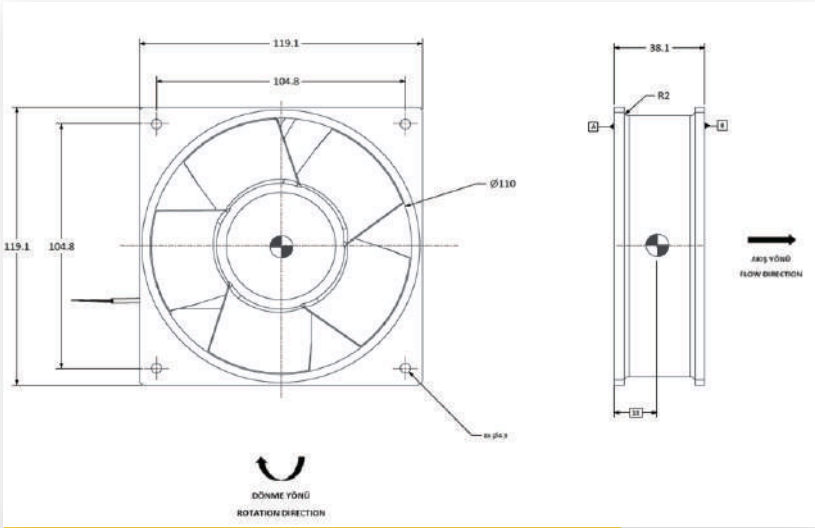

Drawing 1

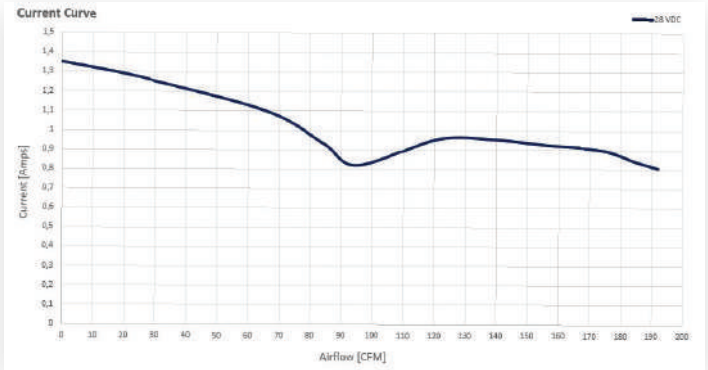
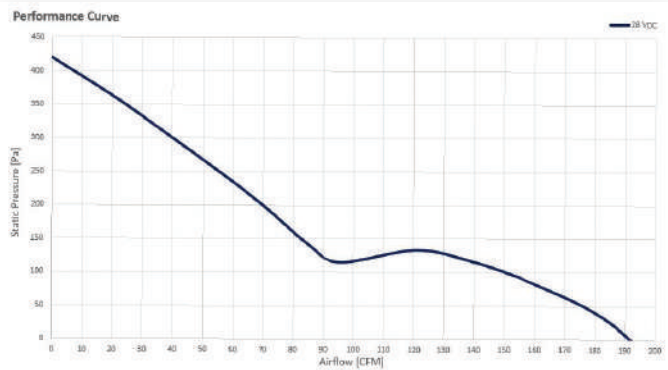

Curve 1

DC FANS

JUPITER150

FAN NAME	PART NUMBER	AIRFLOW [CFM]	SPEED [RPM]	SUPPLY VOLTAGE [VDC]	NOMINAL CURRENT [AMPS]	WEIGHT [GRAMS]	SOUND PRESSURE LEVEL [dB]	PERFORMANCE CURVE	OUTLINE DRAWING	OUTPUT SIGNAL	SPEED CONTROL [PWM]
Jupiter150-002	100657-002	460	6000	28	3.45	850 ± 85	-	Curve 1	Drawing 1	FPS	-
Jupiter150-003	100657-003	386	5100	28	2.1	850 ± 85	-	Curve 2	Drawing 1	FPS	-

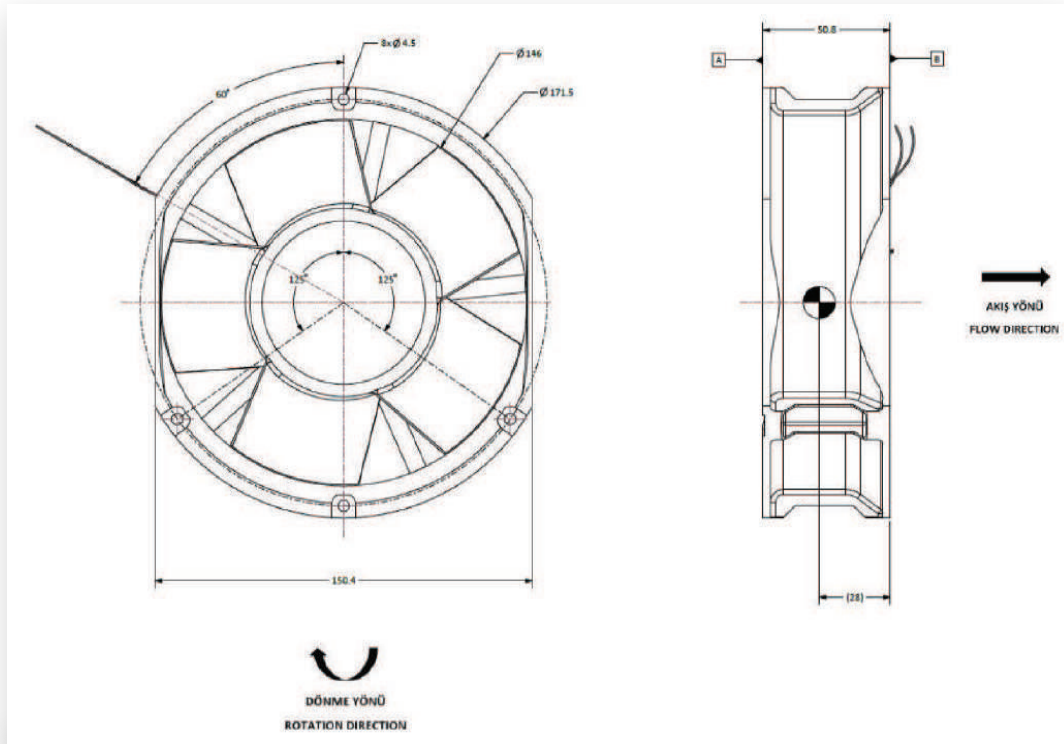

Drawing 1

DC FANS

JUPITER150

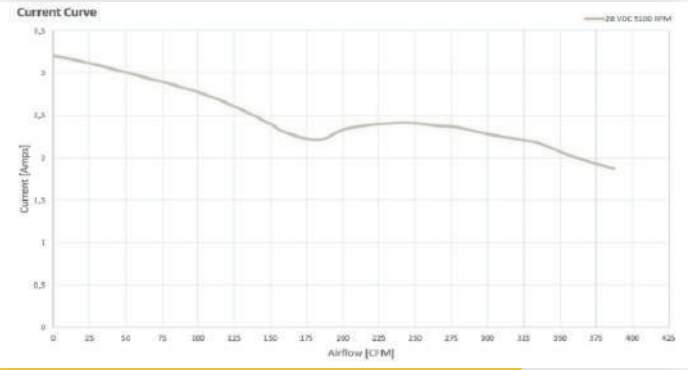
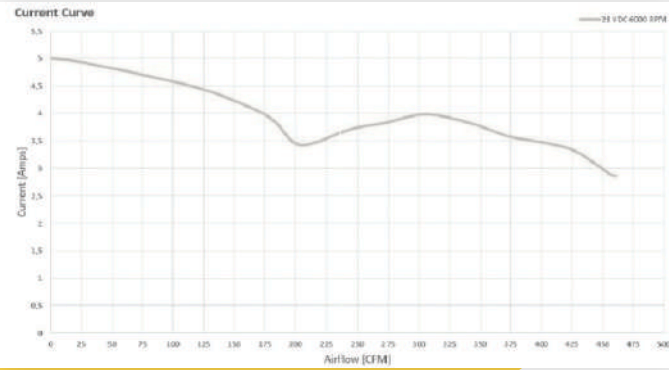
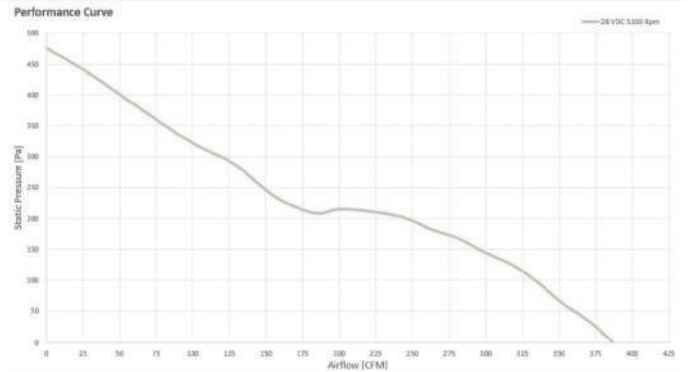
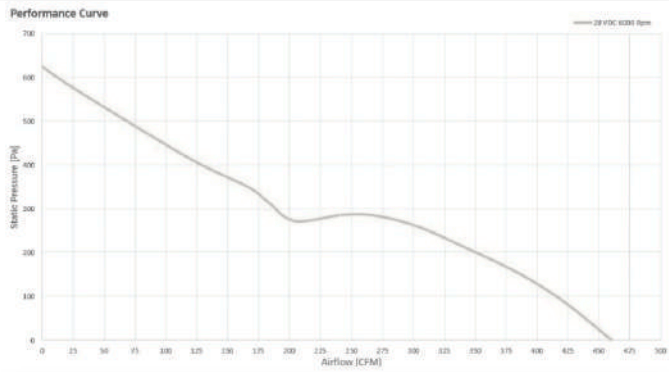

Curve 1

Curve 2

AC FANS

JUPITER150

FAN NAME	PART NUMBER	AIRFLOW [CFM]	SPEED [RPM]	SUPPLY VOLTAGE [VAC]	FREQUENCY [AMPS]	POWER [WATTS]	WEIGHT [GRAMS]	SOUND PRESSURE LEVEL [dB]	PERFORMANCE CURVE	OUTLINE DRAWING	OUTPUT SIGNAL	SPEED CONTROL [PWM]
Jupiter150-001	100657-001	244	3300	230	50-400	22	850 ± 85	-	Curve 1	Drawing 1	-	-
Jupiter150-004	100657-004	266	3600	115	50-400	28	850 ± 85	-	Curve 2	Drawing 1	-	-

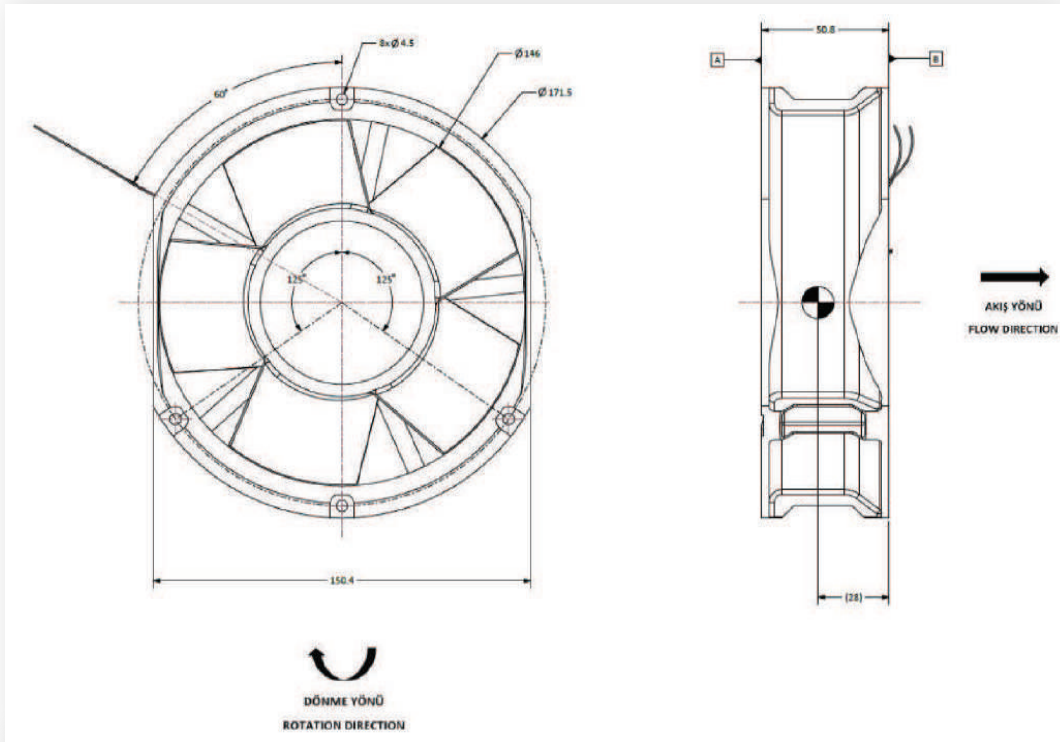

Drawing 1

AC FANS

JUPITER150

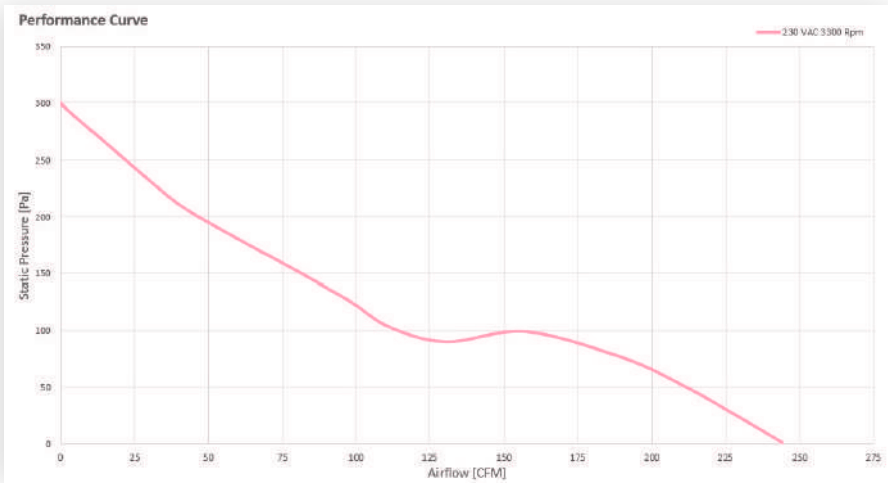

Curve 1

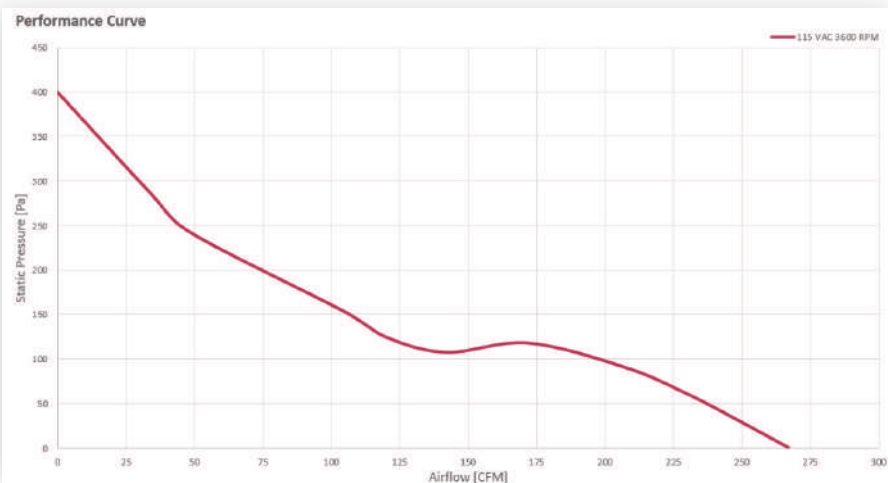

Curve 2

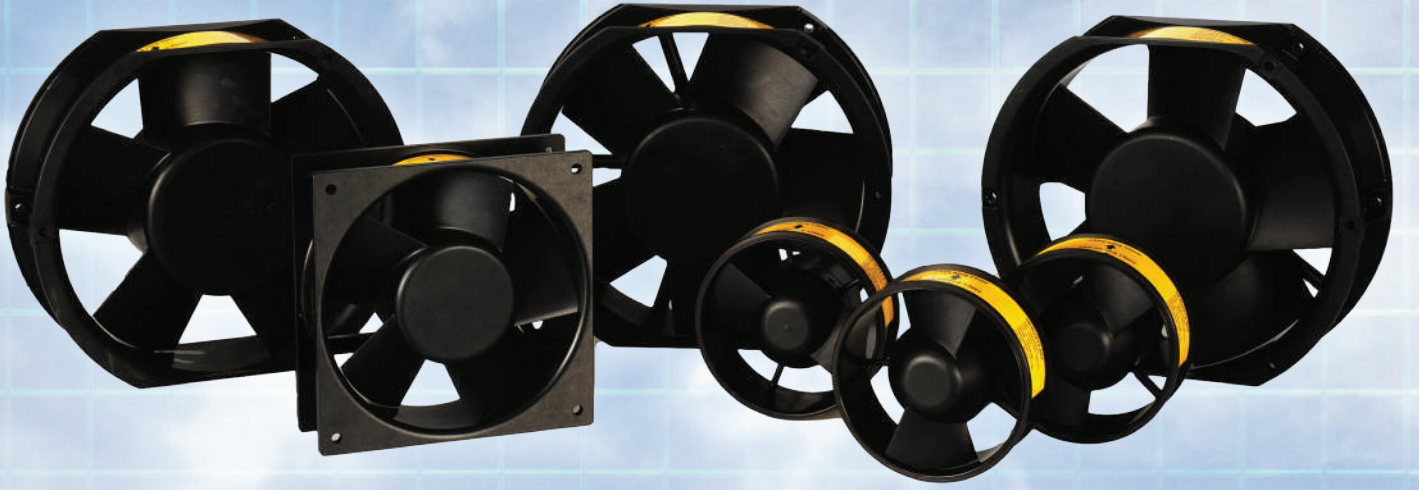

www.anova.com.tr

Anova Merkez Ofis

ODTÜ MET Yerleşkesi
Mustafa Kemal Mahallesi
Dumlupınar Bulvarı
Bina No: 280 B Blok No: 16
Çankaya / ANKARA

Fabrika

Ankara Sanayi Odası
1. OSB, Babürşah Caddesi, No: 10
06935 Sincan / ANKARA