

MILITARY FAN PRODUCT FAMILY



 www.anova.com.tr

 info@anova.com.tr

 +90 312 210 1245

ODTÜ MET Yerleşkesi,
Mustafa Kemal Mah. 2082 Cad.
No: 54/2/16 Çankaya/ANKARA/TÜRKİYE

R&D
Today For
Tomorrow



CONTENTS

SPECIFICATIONS OF THE FANS	1
ENVIRONMENTAL SPECIFICATIONS	1
ELECTROMAGNETIC SPECIFICATIONS	2
<hr/>	
CUSTOM DESIGN OPTIONS	2
MECHANICAL INTERFACE	2
ELECTRICAL INTERFACE	2
NOMINAL VOLTAGE RANGE	2
SPEED SIGNAL	2
INPUT SIGNAL	2
<hr/>	
FAN PERFORMANCE CURVES	3
<hr/>	
DC FANS	4
MERCURY38	4
MARS47	6
VENUS72	8
VENUS75	9
NEPTUNE78	11
NEPTUNE96	12
URANUS110	15
JUPITER150	17
<hr/>	
AC FANS	20
JUPITER150	20
<hr/>	

SPECIFICATIONS OF THE FANS

- The fans are designed to meet the required military standards (MIL-STD-810, MIL-STD-461, MIL-B-28873) and harsh ambient conditions.
- The fans are designed in accordance with ISO 1940-1 standards for the required balances.
- The case and rotor parts of the fans are made of AL6061-T6 material with five axis CNC machine and stainless steel is used as shaft material.
- Two high precision ball bearings with integrated lubricant which is suitable for operation at -54 degrees Celsius with stainless steel cover are used in the fans.
- All fans are coated in accordance with MIL-A-8625F and MIL-C-5541 standards.
- The fans receive their power from brushless DC or AC motors which are designed by ANOVA. The fans have high efficiency, vector-controlled drives which are designed by ANOVA.
- The fans have speed information and error signal feedback options.
- Performance tests of the fans are carried out within ANOVA in accordance with AMCA-210 standard.

ENVIRONMENTAL SPECIFICATIONS

These fans can be designed to meet the requirements of MIL-STD-704 and the following requirements of MIL-STD-810G-CHG-1;

Op. Temperature: Method 502.6 Procedure II, 501.6 Procedure II

St. Temperature: Method 502.6 Procedure I, 501.6 Procedure I

Acceleration: Method 513.7 Procedure II

Vibration: Method 514.7 Procedure I

Shock: Method 516.7 Procedure I

Salt Fog: Method 509.6

Rain: Method 506.6 Procedure I

Fungus: Method 508.7

Humidity: Method 507.6 Procedure II

Altitude: Method 500.6 Procedure II

Temp. Shock: Method 503.6 Procedure I

Fluid Contamination: Method 504.2

ELECTROMAGNETIC SPECIFICATIONS

These fans can be designed to meet the following requirements of MIL-STD-461E/F;

MIL-STD-461E/F REQUIREMENTS	TEST LIMITS
CE102, Conducted Emissions, power leads, 10 kHz to 10 MHz	Figure CE102-1
CS101, Conducted Susceptibility, power leads, 30 Hz to 150 kHz	Figure CS101-1
CS114, Conducted Susceptibility, bulk cable injection, 10 kHz to 200 MHz	Figure CS114-1
CS115, Conducted Susceptibility, bulk cable injection, impulse excitation	Figure CS115-1
CS116, Conducted Susceptibility, damped sinusoidal transients, cables and power leads, 10 kHz to 100 MHz	Figure CS116-1
RE102, Radiated Emissions, electric field, 10 kHz to 18 GHz	Figure RE102-3, Fixed Wing Internal, < 25 meters Nose to Tail
RS103, Radiated Susceptibility, Electric Field, 2 MHz to 18 GHz	Table VII, Aircraft Internal, 2 MHz-30 MHz: 20 V/m; 30 MHz-1 GHz: 20 V/m; 1 GHz-18 GHz: 60 V/m

CUSTOM DESIGN OPTIONS

ANOVA is capable of designing your FANS for different requirements and standards. We are flexible in designing custom products for your needs in short periods.

MECHANICAL INTERFACE	ELECTRICAL INTERFACE	NOMINAL VOLTAGE RANGE
Custom Flange	Flying Leads	12 VDC to 28 VDC
	Connector	
SPEED SIGNAL	INPUT SIGNAL	
FPS (Tach Output)	PWM Speed Control	
LSWD (Low Speed Warning Detection)		

FAN PERFORMANCE CURVE

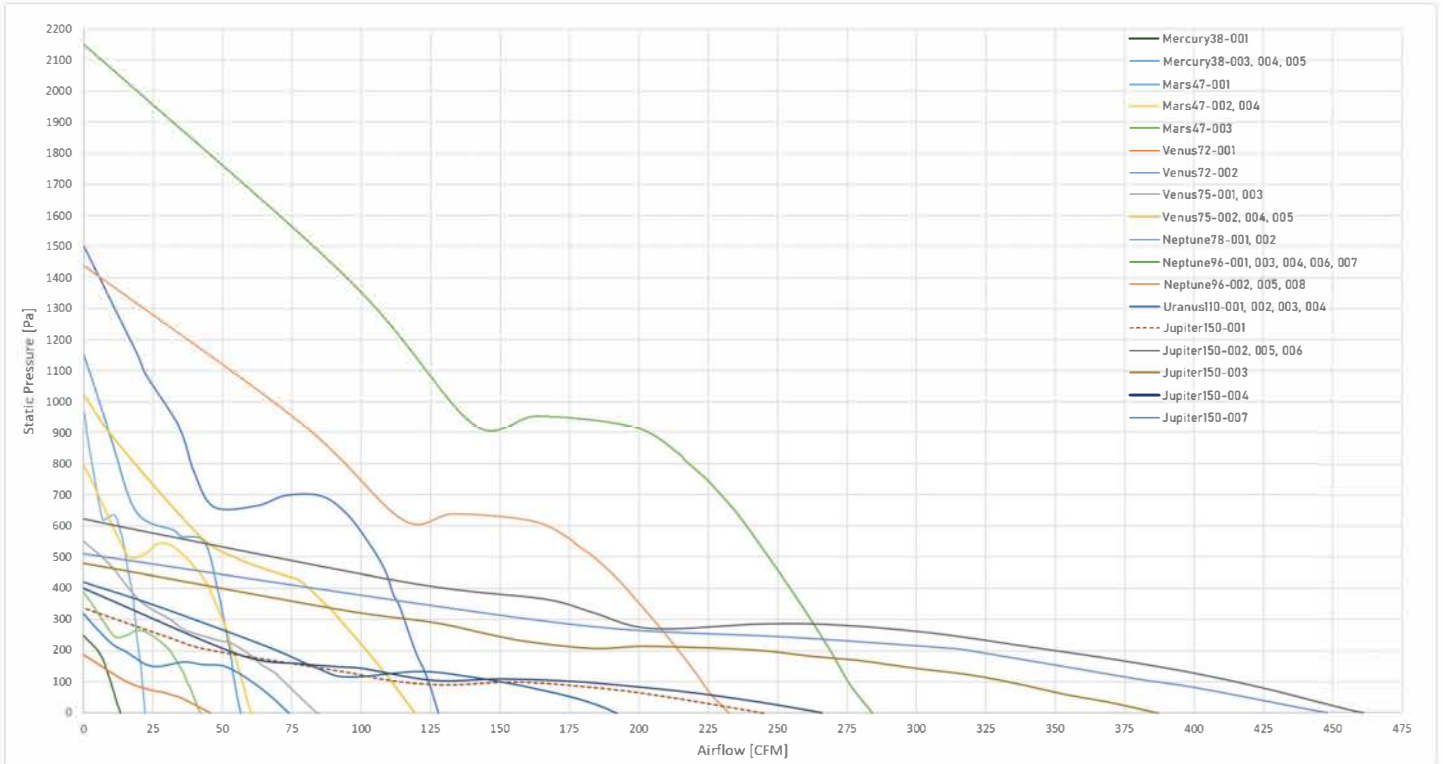

(@Air density=1,202 kg/m³)

DC FANS

MERCURY38

FAN NAME	PART NUMBER	MAXIMUM AIRFLOW [CFM]	MAXIMUM PRESSURE [PA]	SPEED [RPM]	SUPPLY VOLTAGE [VDC]	NOMINAL CURRENT [AMPS]	NOMINAL POWER [W]	WEIGHT [GRAMS]	SOUND PRESSURE LEVEL [DB]	PERFORMANCE CURVE	OUTLINE DRAWING [MM]	OUTPUT SIGNAL	SPEED CONTROL [PWM]
Mercury38-001	100967-001	13,4	248	17000	28	0,2	5,6	95 ± 10	64,3	1	Drawing 1	FPS	
Mercury38-003	100967-003	22,2	966	27700	28	0,57	15,96	95 ± 10	76	2	Drawing 1	FPS LSWD	
Mercury38-004	100967-004	22,2	966	27700	28	0,57	15,96	85 ± 10	76	2	Drawing 2	FPS	PWM
Mercury38-005	100967-005	22,2	966	27700	28	0,57	15,96	95 ± 10	76	2	Drawing 1	FPS	PWM

Drawing 1

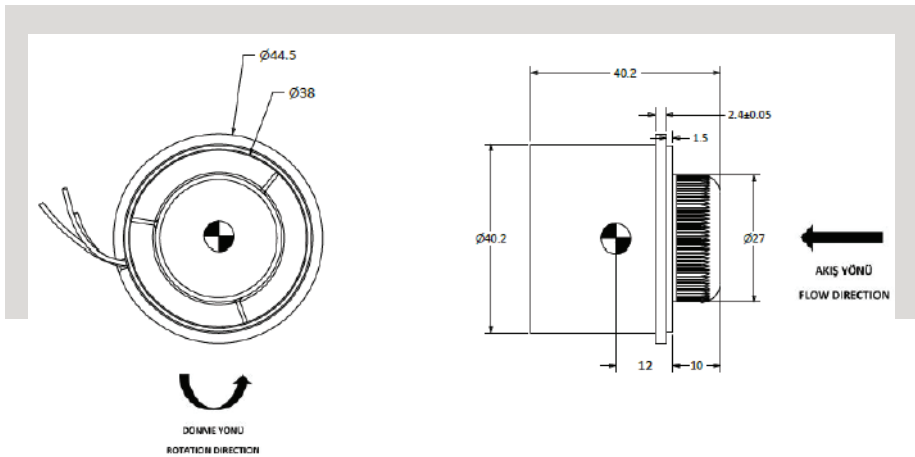

Drawing 2

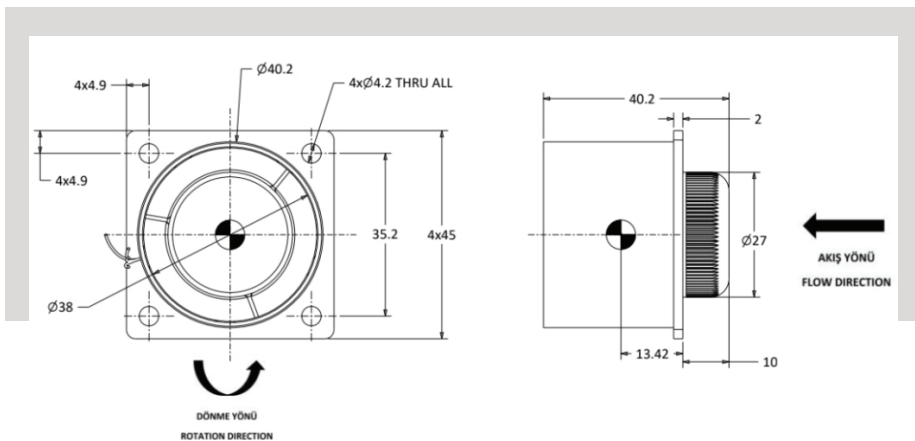

DC FANS

MERCURY38

Curve 1

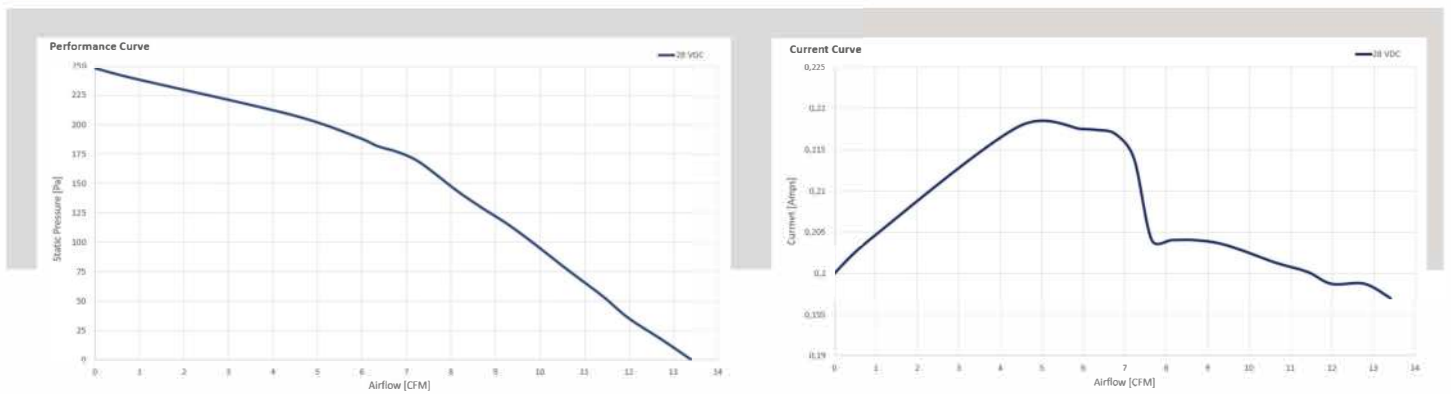

Curve 2

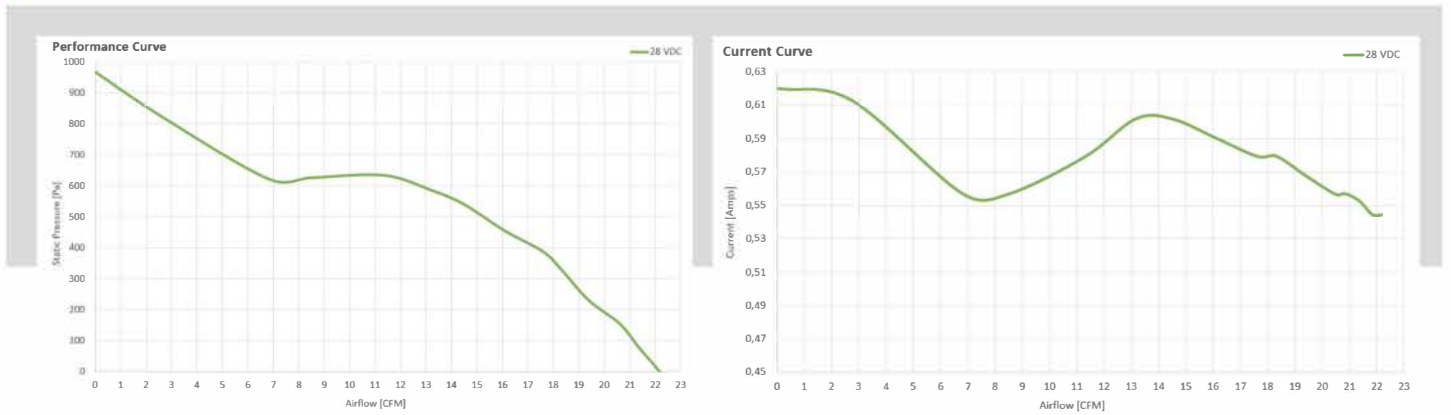

DC FANS

MARS47

FAN NAME	PART NUMBER	MAXIMUM PRESSURE [PA]	AIRFLOW [CFM]	SPEED [RPM]	SUPPLY VOLTAGE [VDC]	NOMINAL CURRENT [AMPS]	NOMINAL POWER [W]	WEIGHT [GRAMS]	SOUND PRESSURE LEVEL [DB]	PERFORMANCE CURVE	OUTLINE DRAWING [MM]	OUTPUT SIGNAL	SPEED CONTROL [PWM]
Mars47-001	100205-001	1150	57	21500	28	1,4	39,2	125 ± 15	73	1	Drawing 1	FPS	
Mars47-002	100205-002	795	61	21200	28	1,4	39,2	125 ± 15		2	Drawing 2	FPS	
Mars47-003	100205-003	387	42	15000	28	0,475	13,3	125 ± 15		3	Drawing 3	FPS	
Mars47-004	100205-004	795	61	21200	28	1,4	39,2	125 ± 15		2	Drawing 3	FPS	

Drawing 1

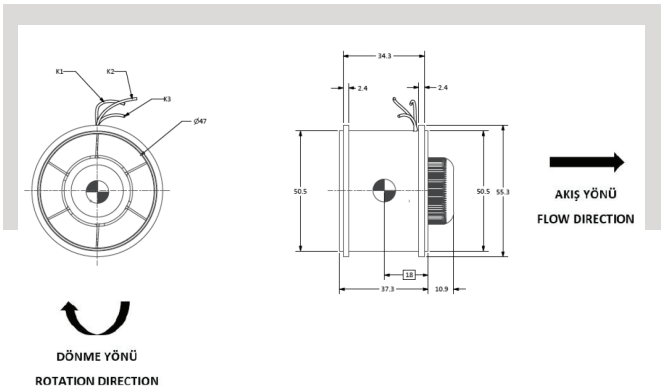

Drawing 2

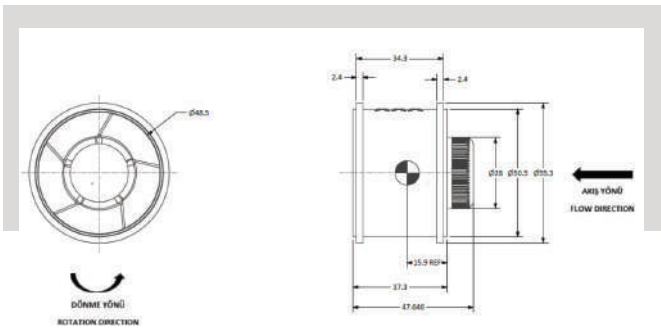

Drawing 3

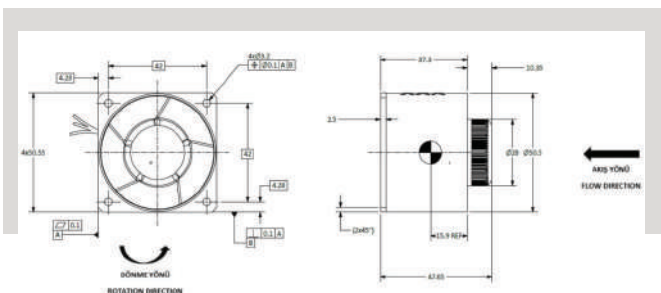

DC FANS

MARS47

Curve 1

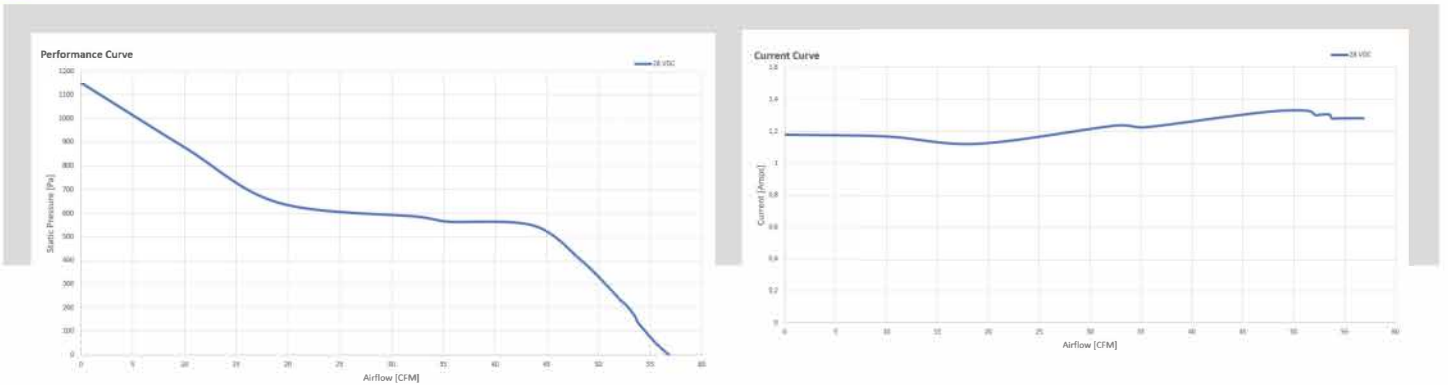

Curve 2

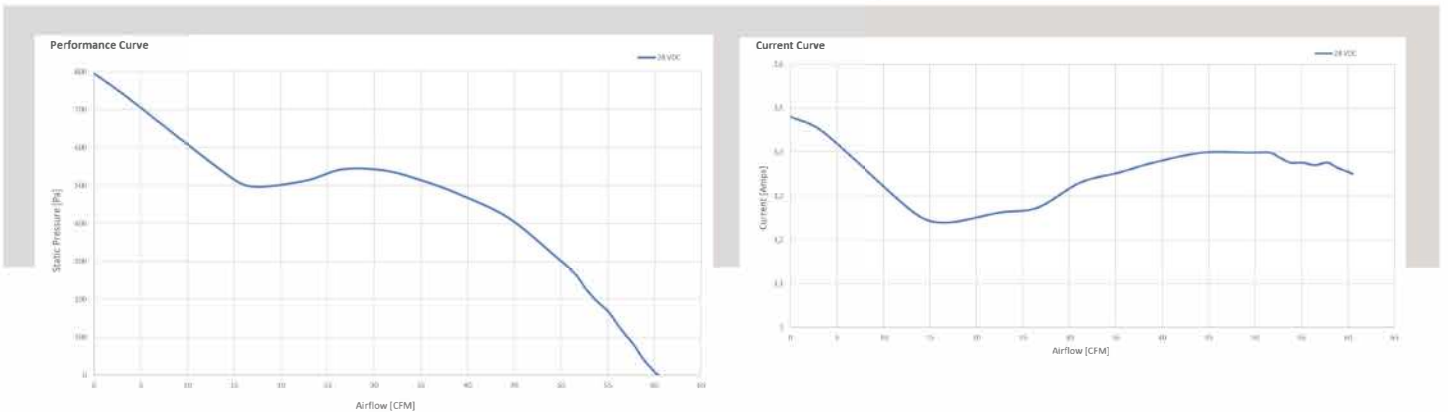

Curve 3

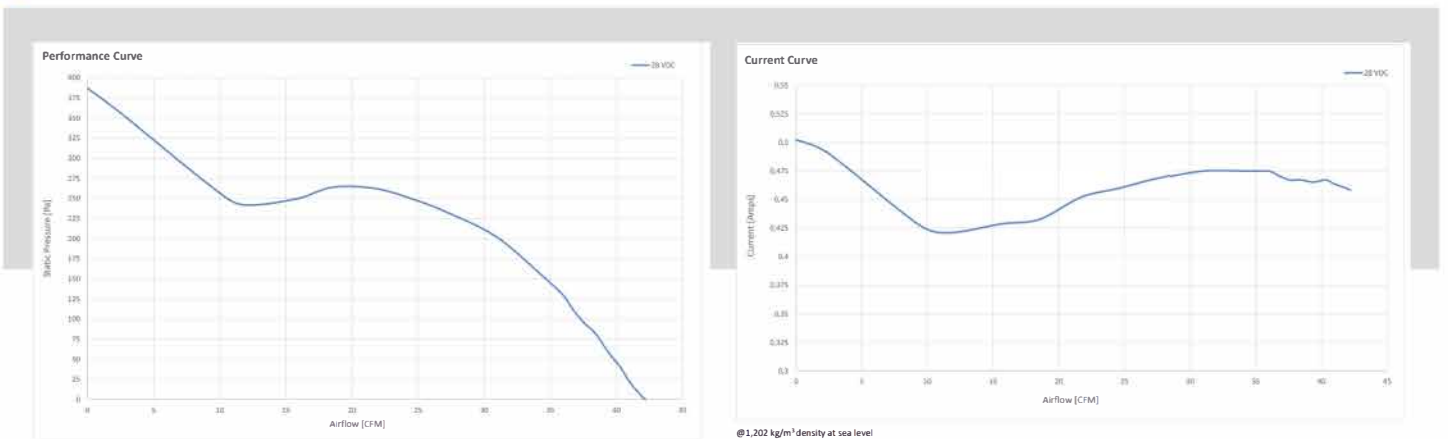

@1.202 kg/m³ density at sea level

@1.202 kg/m³ density at sea level

DC FANS

VENUS72

FAN NAME	PART NUMBER	AIRFLOW [CFM]	MAXIMUM PRESSURE [PA]	SPEED [RPM]	SUPPLY VOLTAGE [VDC]	NOMINAL CURRENT [AMPS]	NOMINAL POWER [W]	WEIGHT [GRAMS]	SOUND PRESSURE LEVEL [DB]	PERFORMANCE CURVE	OUTLINE DRAWING [MM]	OUTPUT SIGNAL	SPEED CONTROL [PWM]
Venus72-001	101091-001	46,5	188	4700	28	0,16	4,48	200 ± 25	52	1	Drawing 1	FPS	
Venus72-002	101091-002	75	318	7500	28	0,66	18,48	200 ± 25		2	Drawing 1	FPS	

Drawing 1

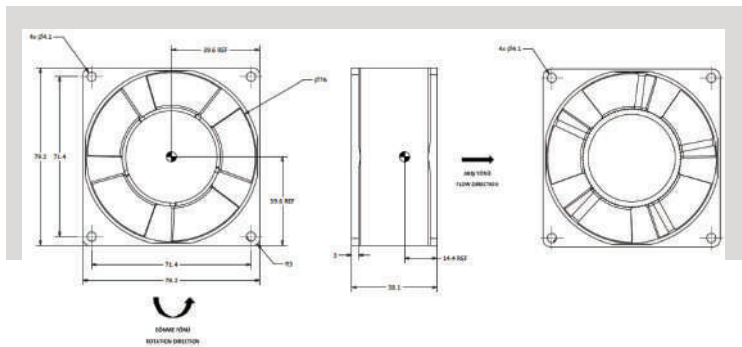

Curve 1

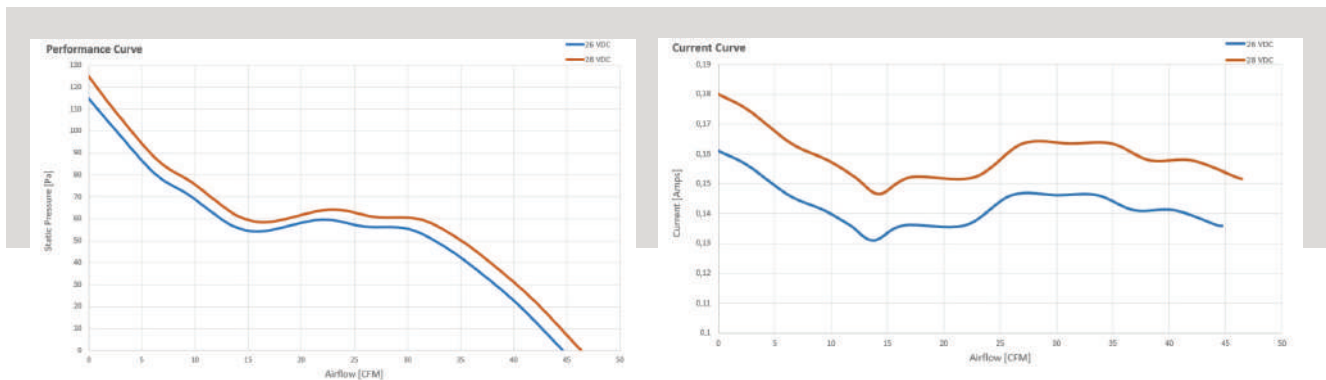

Curve 2

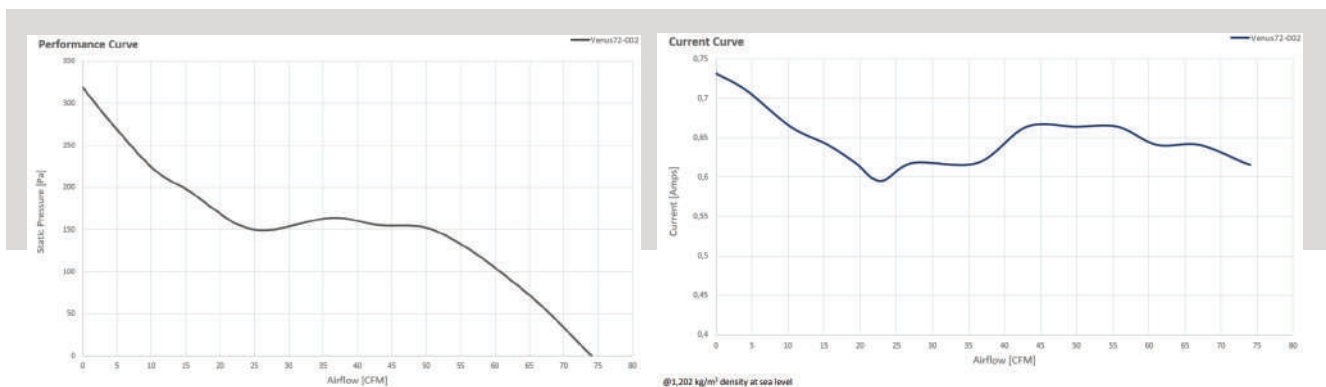

DC FANS

VENUS75

FAN NAME	PART NUMBER	AIRFLOW [CFM]	MAXIMUM PRESSURE [PA]	SPEED [RPM]	SUPPLY VOLTAGE [VDC]	NOMINAL CURRENT [AMPS]	NOMINAL POWER [W]	WEIGHT [GRAMS]	SOUND PRESSURE LEVEL [DB]	PERFORMANCE CURVE	OUTLINE DRAWING [MM]	OUTPUT SIGNAL	SPEED CONTROL [PWM]
Venus75-001	100656-001	85	550	13500	28	0,55	15,4	155 ± 15	70	1	Drawing 1	LSWD	
Venus75-002	100656-002	119	1020	19000	28	1,3	36,4	155 ± 15	76	2	Drawing 1	FPS	
Venus75-003	100656-003	85	550	13500	28	0,55	15,4	155 ± 15	70	1	Drawing 1	LSWD	
Venus75-004	100656-004	119	1020	19000	28	1,3	36,4	155 ± 15	76	2	Drawing 1	FPS	
Venus75-005	100656-005	119	1020	19000	28	1,3	36,4	155 ± 15	76	2	Drawing 1	LSWD	

Drawing 1

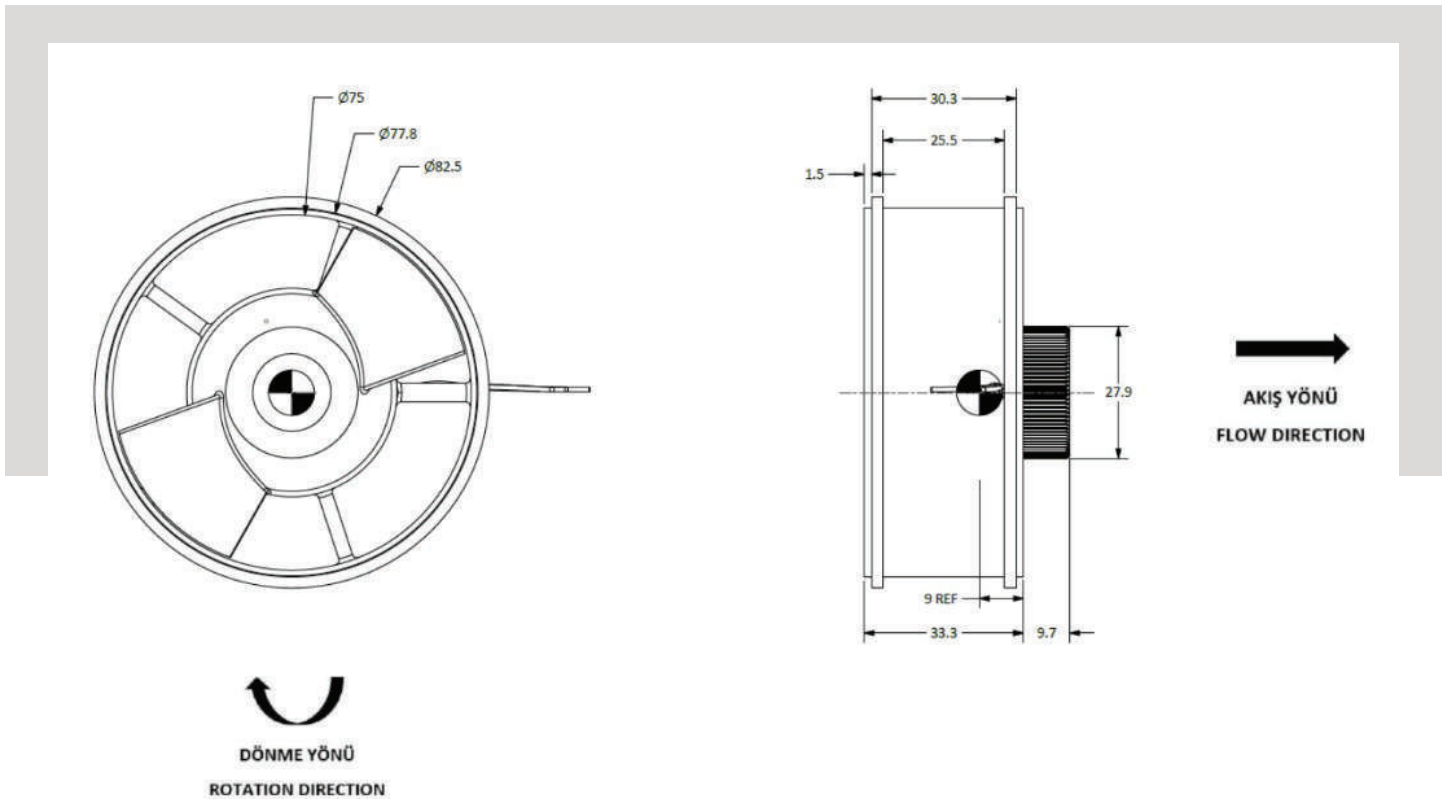

DC FANS

VENUS75

Curve 1

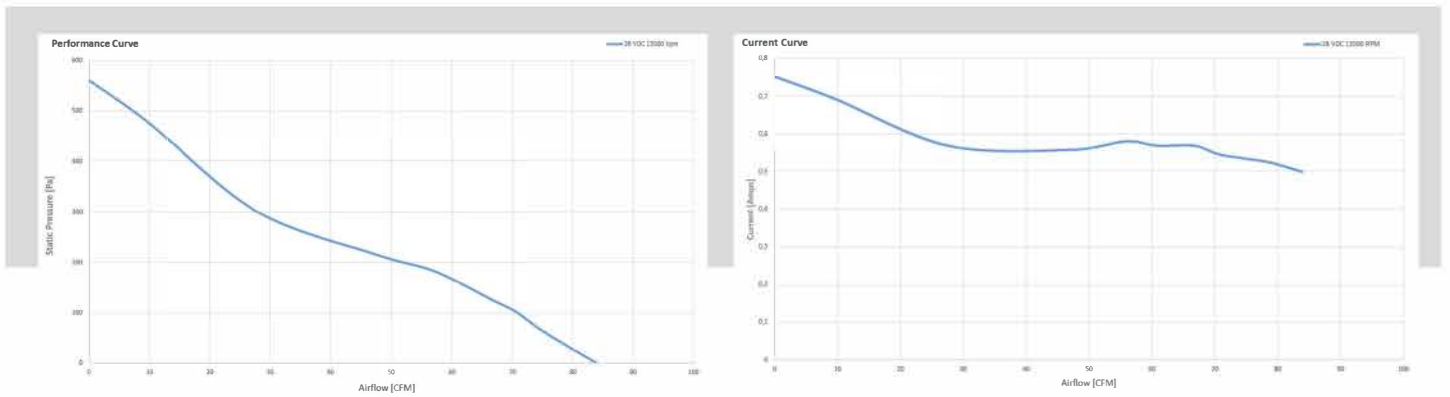

Curve 2

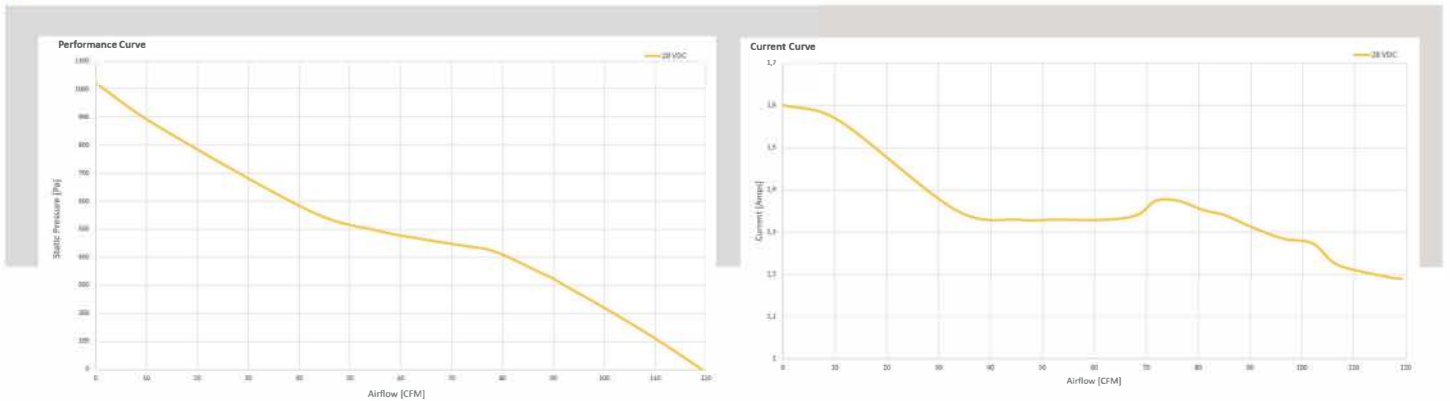

DC FANS

NEPTUNE78

FAN NAME	PART NUMBER	AIRFLOW [CFM]	MAXIMUM PRESSURE [PA]	SPEED [RPM]	SUPPLY VOLTAGE [VDC]	NOMINAL CURRENT [AMPS]	NOMINAL POWER [W]	WEIGHT [GRAMS]	SOUND PRESSURE LEVEL [DB]	PERFORMANCE CURVE	OUTLINE DRAWING [MM]	OUTPUT SIGNAL	SPEED CONTROL [PWM]
Neptune78-001	102102-001	128	1500	16500	28	2,75	77	460 ± 50		1	Drawing 1	FPS	
Neptune78-002	102102-002	128	1500	16500	28	2,75	77	460 ± 50		1	Drawing 1	FPS	

Drawing 1

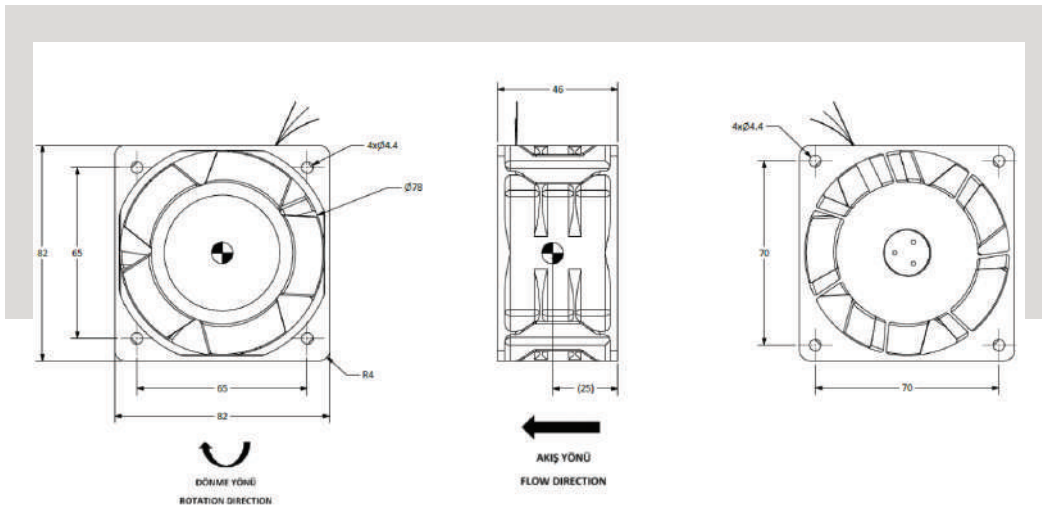

Curve 1

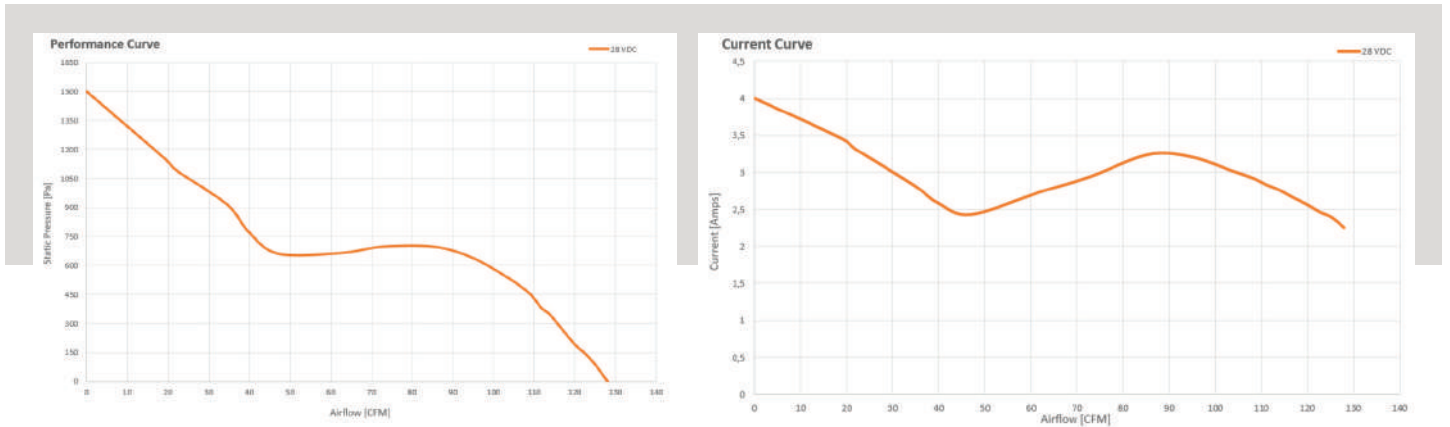

DC FANS

NEPTUNE96

FAN NAME	PART NUMBER	MAXIMUM PRESSURE [PA]	AIRFLOW [CFM]	SPEED [RPM]	SUPPLY VOLTAGE [VDC]	NOMINAL CURRENT [AMPS]	NOMINAL POWER [W]	WEIGHT [GRAMS]	SOUND PRESSURE LEVEL [DB]	PERFORMANCE CURVE	OUTLINE DRAWING [MM]	OUTPUT SIGNAL	SPEED CONTROL [PWM]
Neptune96-001	100204-001	2150	288	16500	28	6	168	500 ± 50	86,7	1	Drawing 1		
Neptune96-002	100204-002	1440	232	13500	28	3,5	98	500 ± 50		2	Drawing 2	FPS	
Neptune96-003	100204-003	2150	288	16500	28	6	168	500 ± 50	86,7	1	Drawing 1	LSWD	PWM
Neptune96-004	100204-004	2150	288	16500	28	6	168	500 ± 50	86,7	1	Drawing 4	FPS	
Neptune96-005	100204-005	1440	232	13500	28	3,5	98	500 ± 50		2	Drawing 1	FPS	
Neptune96-006	100204-006	2200	306	16700	28	6	168	510 ± 50	86,7	3	Drawing 3	FPS	PWM
Neptune96-007	100204-007	2150	288	16500	28	6	168	500 ± 50	88	1	Drawing 5	FPS	
Neptune96-008	100204-008	1440	232	13500	28	3,5	98	500 ± 50		2	Drawing 1	FPS	

Drawing 1

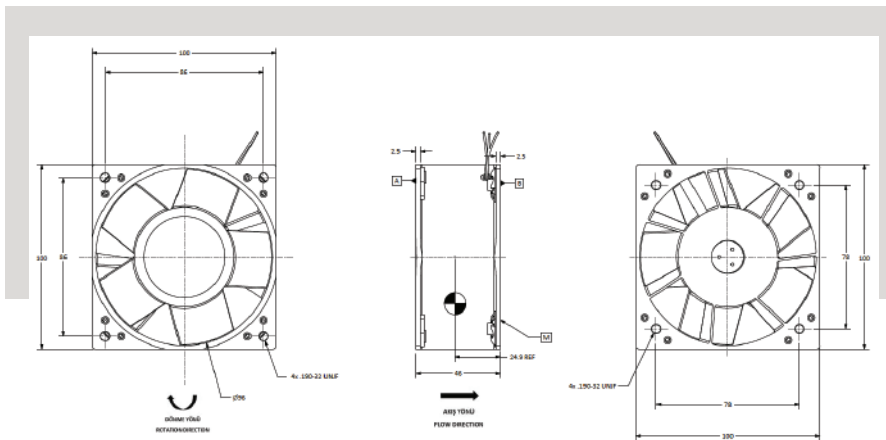

Drawing 2

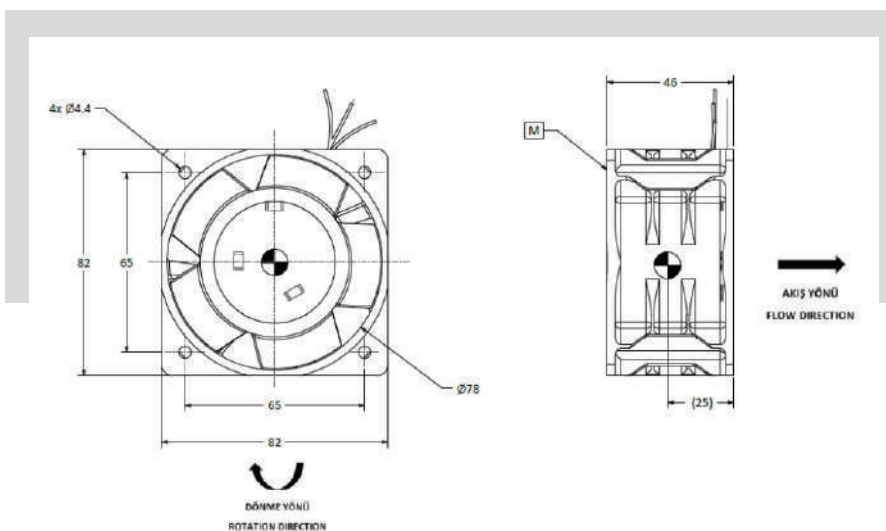

DC FANS

NEPTUNE96

Drawing 3

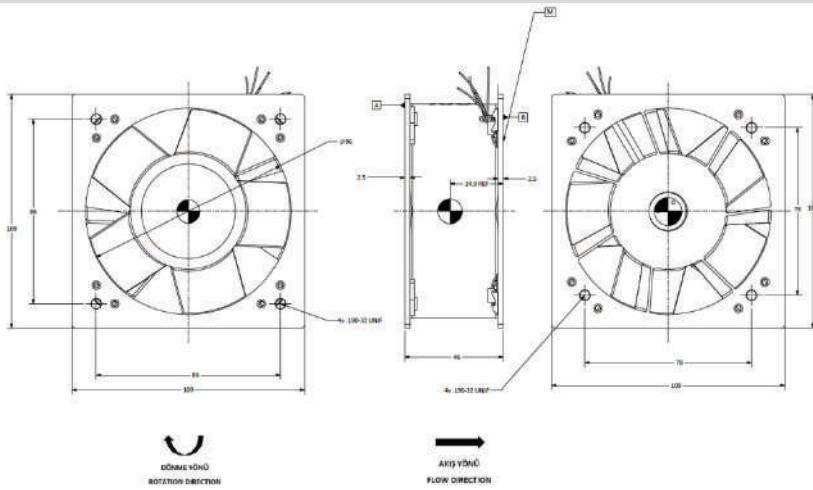

Drawing 4

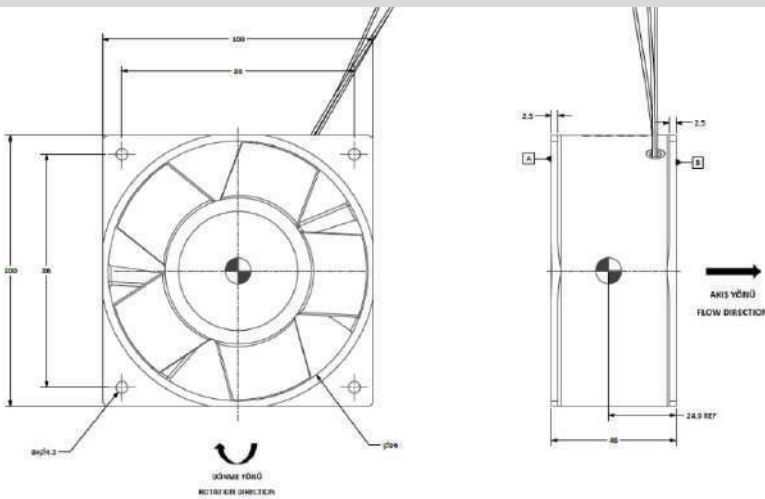

Drawing 5

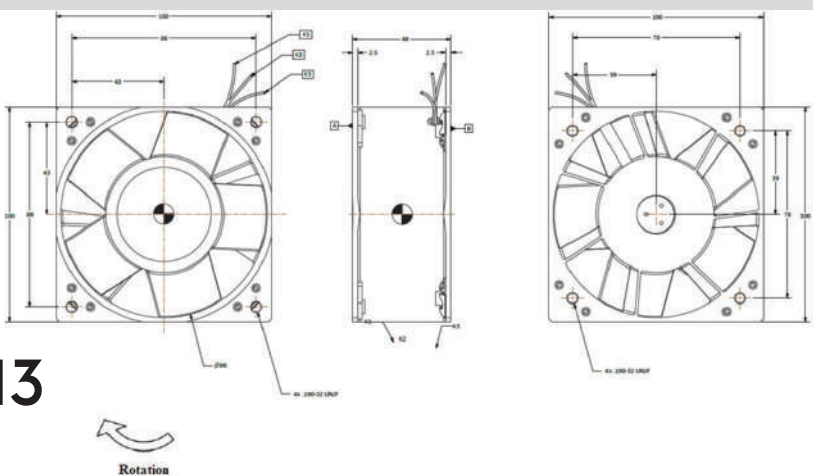

DC FANS

NEPTUNE96

Curve 1

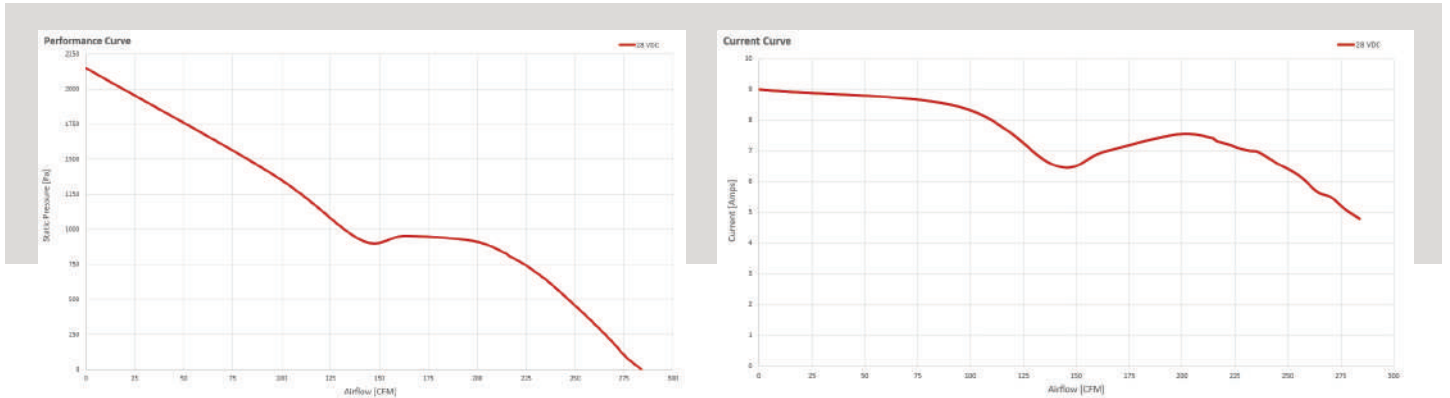

Curve 2

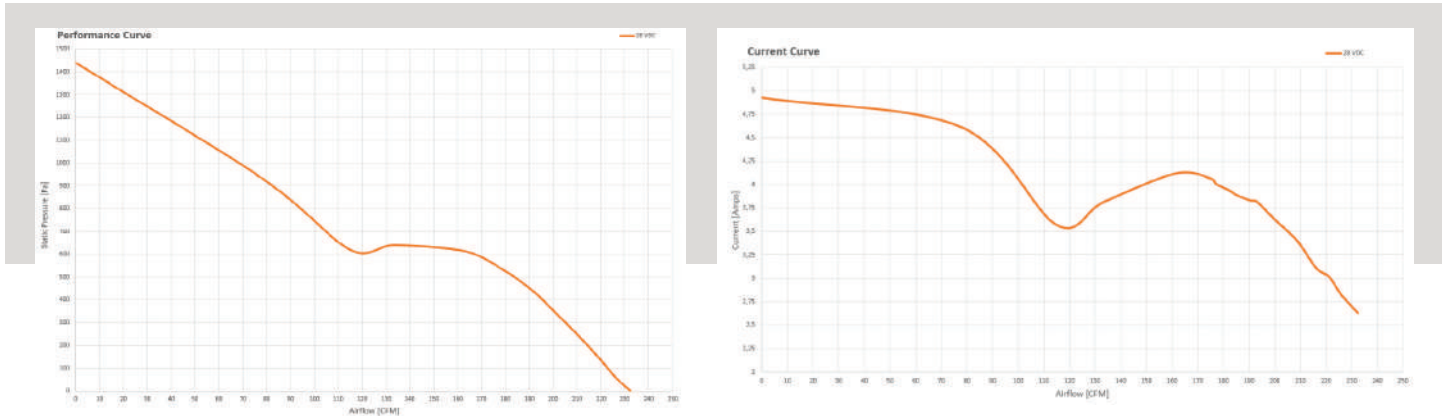

Curve 3

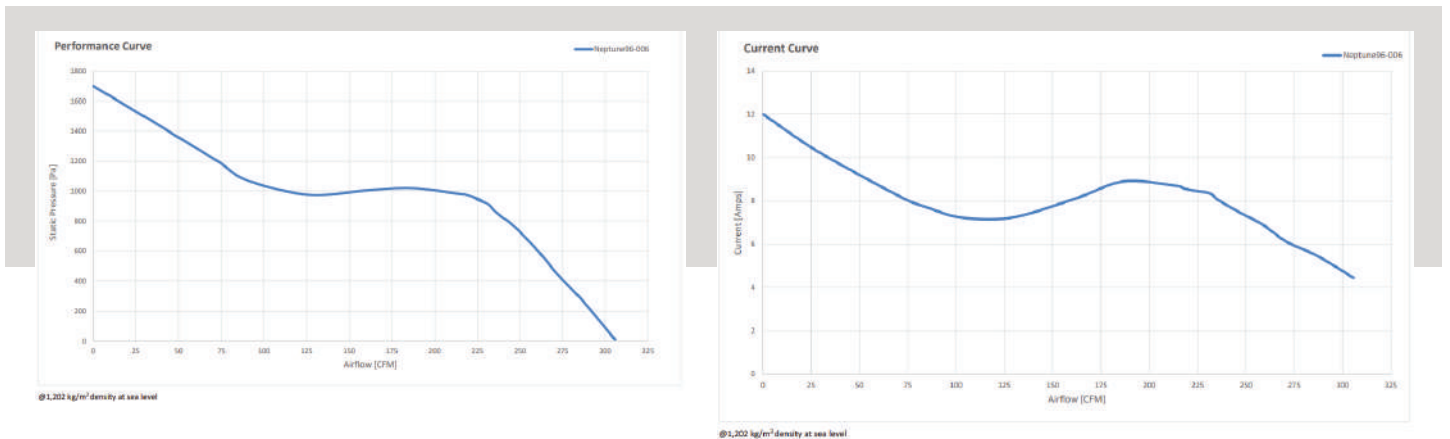

DC FANS

URANUS110

FAN NAME	PART NUMBER	MAXIMUM AIRFLOW [CFM]	MAXIMUM PRESSURE [PA]	SPEED [RPM]	SUPPLY VOLTAGE [VDC]	NOMINAL CURRENT [AMPS]	NOMINAL POWER [W]	WEIGHT [GRAMS]	SOUND PRESSURE LEVEL [DB]	PERFORMANCE CURVE	OUTLINE DRAWING [MM]	OUTPUT SIGNAL	SPEED CONTROL [PWM]
Uranus110-001	100605-001	192	420	5350	28	0,8	22,4	420 ± 40	68	1	Drawing 1	FPS	
Uranus110-002	100605-002	192	420	5350	28	0,8	22,4	420 ± 40	68	1	Drawing 1	FPS (12V)	
Uranus110-003	100605-003	192	420	5350	28	0,8	22,4	420 ± 40	68	1	Drawing 2	FPS	
Uranus110-004	100605-004	192	420	5350	28	0,8	22,4	420 ± 40	68	1	Drawing 2	FPS	

Drawing 1

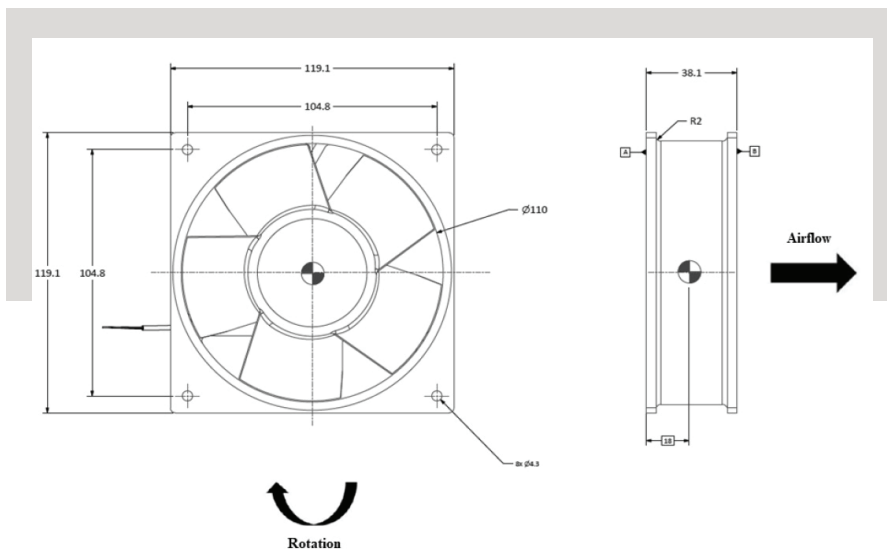

Drawing 2

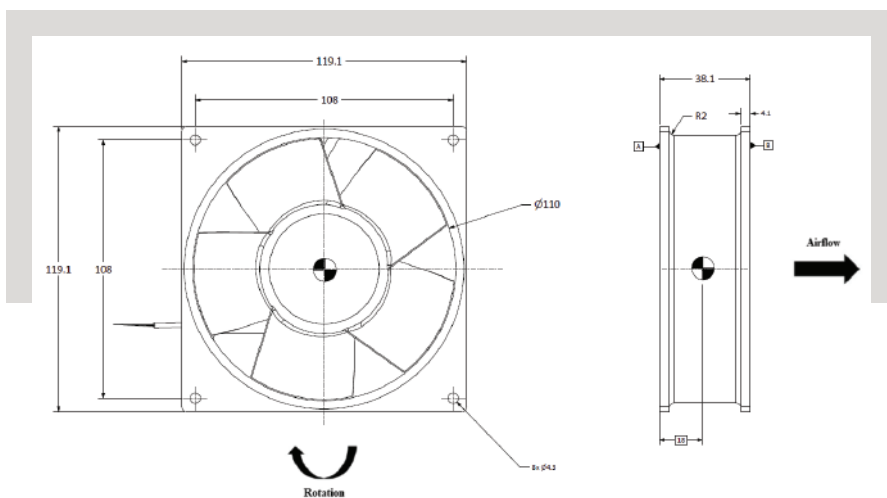

DC FANS

URANUS110

Curve 1

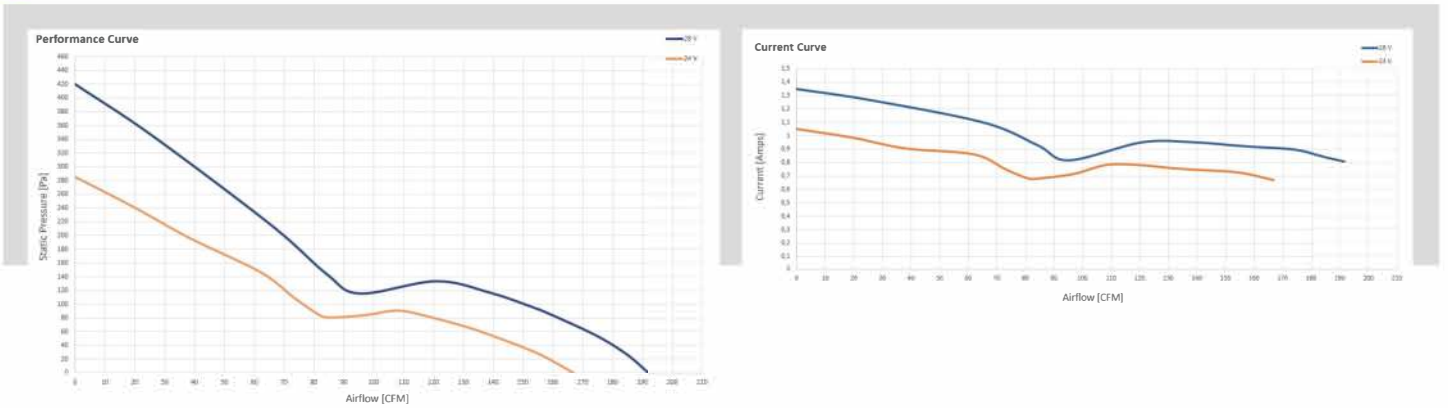

DC FANS

JUPITER150

FAN NAME	PART NUMBER	MAXIMUM AIRFLOW [CFM]	MAXIMUM PRESSURE [PA]	SPEED [RPM]	SUPPLY VOLTAGE [VDC]	NOMINAL CURRENT [AMPS]	NOMINAL POWER [W]	WEIGHT [GRAMS]	SOUND PRESSURE LEVEL [DB]	PERFORMANCE CURVE	OUTLINE DRAWING [MM]	OUTPUT SIGNAL	SPEED CONTROL [PWM]
Jupiter150-002	100657-002	460	620	6000	28	3,45	96,6	850 ± 85	81,7	1	Drawing 1	FPS	
Jupiter150-003	100657-003	386	480	5100	28	2,1	58,8	850 ± 85		2	Drawing 1	FPS	
Jupiter150-005	100657-005	460	620	6000	28	3,45	96,6	850 ± 85	81,7	1	Drawing 1	FPS LSWD	
Jupiter150-006	100657-006	460	620	6000	28	3,45	96,6	850 ± 85	81,7	1	Drawing 1	FPS	
Jupiter150-007	100657-007	448	510	5200	28	2,1	58,8	850 ± 85	75	3	Drawing 2	FPS	

Drawing 1

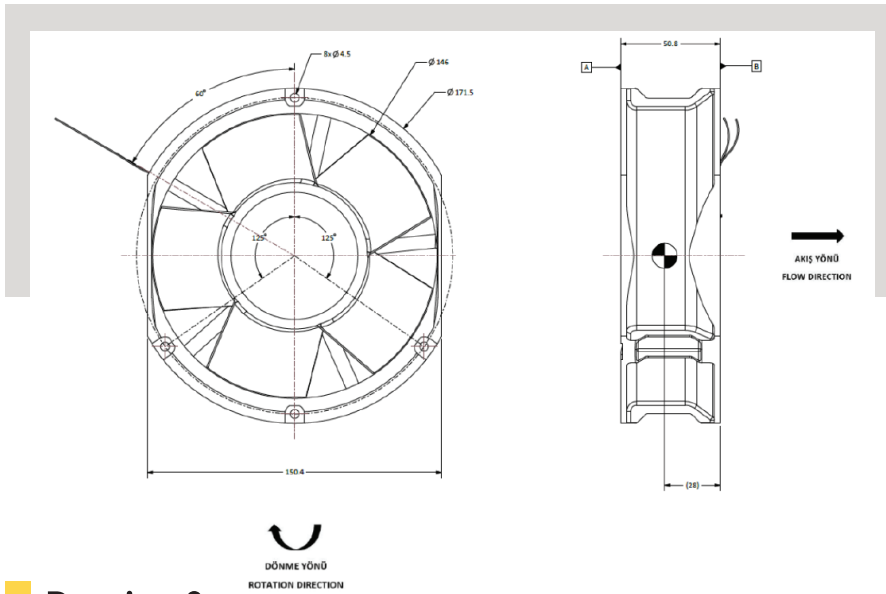

Drawing 2

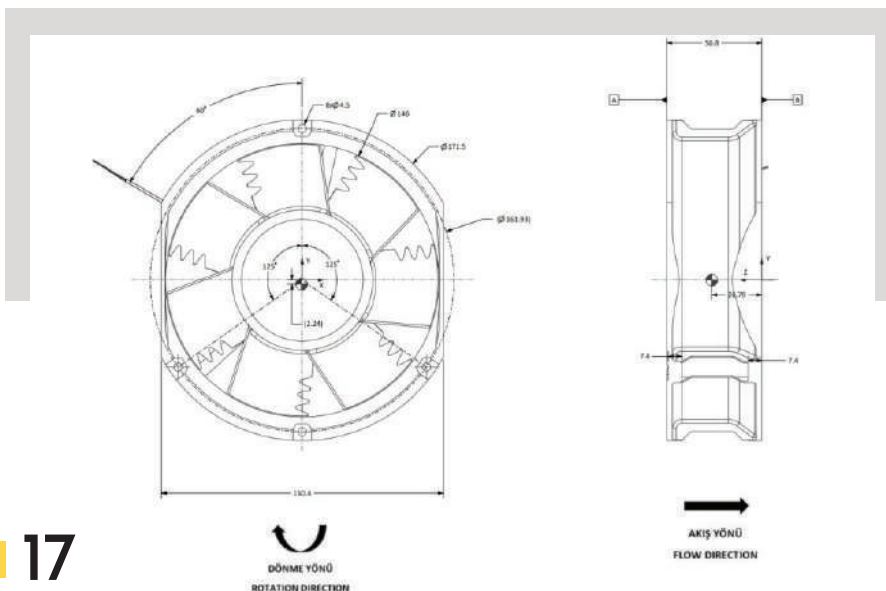

DC FANS

JUPITER150

Curve 1

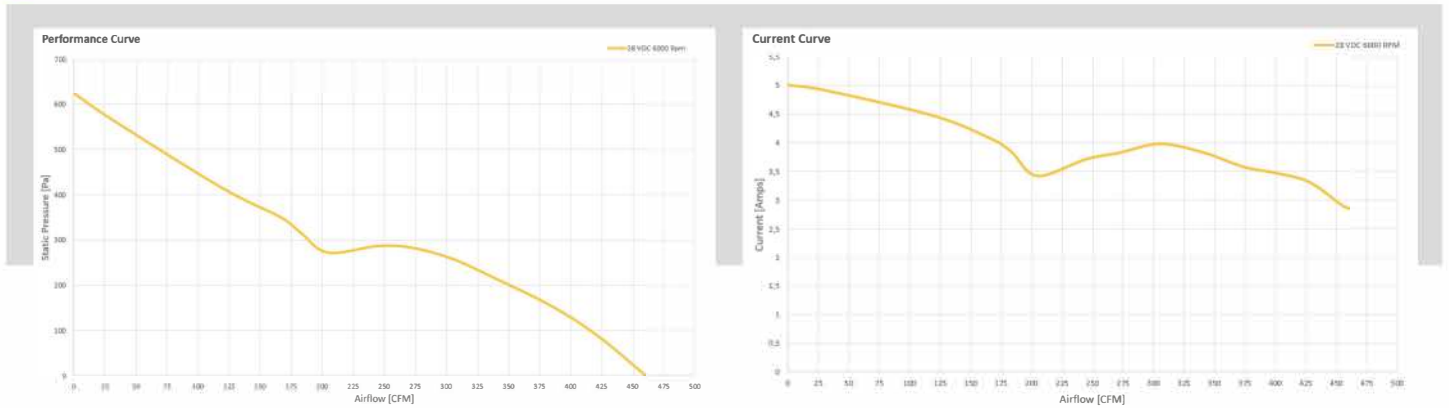

Curve 2

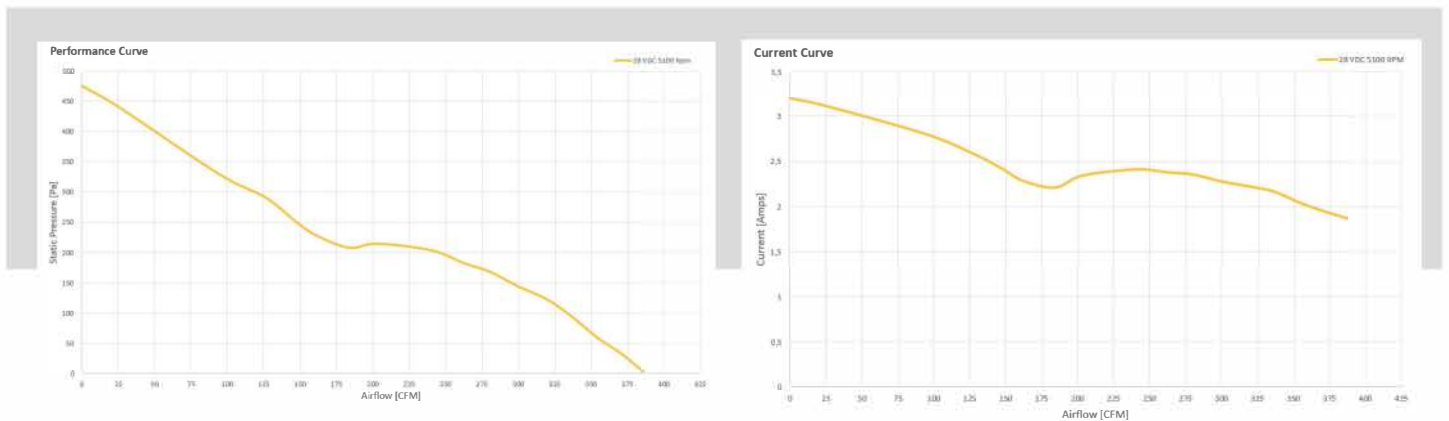

Curve 3

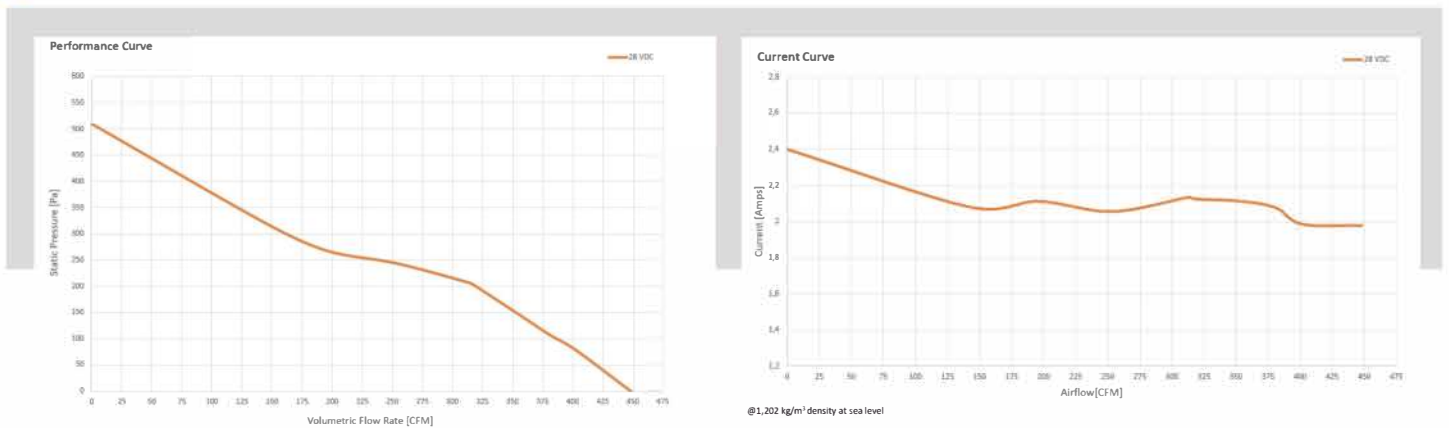

@1,202 kg/m³ density at sea level

@1,202 kg/m³ density at sea level

AC FANS

JUPITER150

FAN NAME	PART NUMBER	AIRFLOW [CFM]	MAXIMUM PRESSURE [PA]	SPEED [RPM]	SUPPLY VOLTAGE [VDC]	FREQUENCY [HZ]	POWER [WATTS]	WEIGHT [GRAMS]	SOUND PRESSURE LEVEL [DB]	PERFORMANCE CURVE	OUTLINE DRAWING [MM]	OUTPUT SIGNAL	SPEED CONTROL [PWM]
Jupiter150-001	100657-001	244	336	3300	230	50-400	22	850 ± 85		1	Drawing 1		
Jupiter150-004	100657-004	266	400	3600	115	50-400	28	850 ± 85		2	Drawing 1	FPS	

Drawing 1

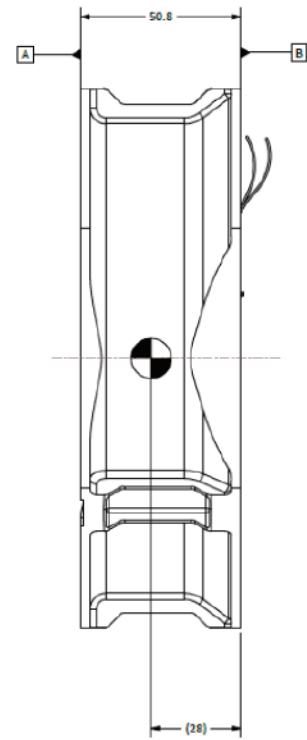
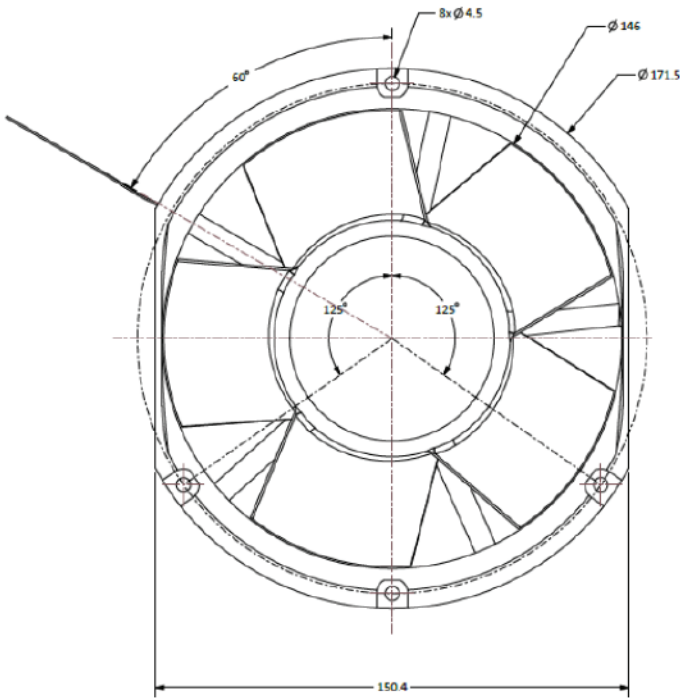

AKIŞ YÖNÜ
FLOW DIRECTION

DÖNME YÖNÜ
ROTATION DIRECTION

AC FANS

JUPITER150

Curve 1

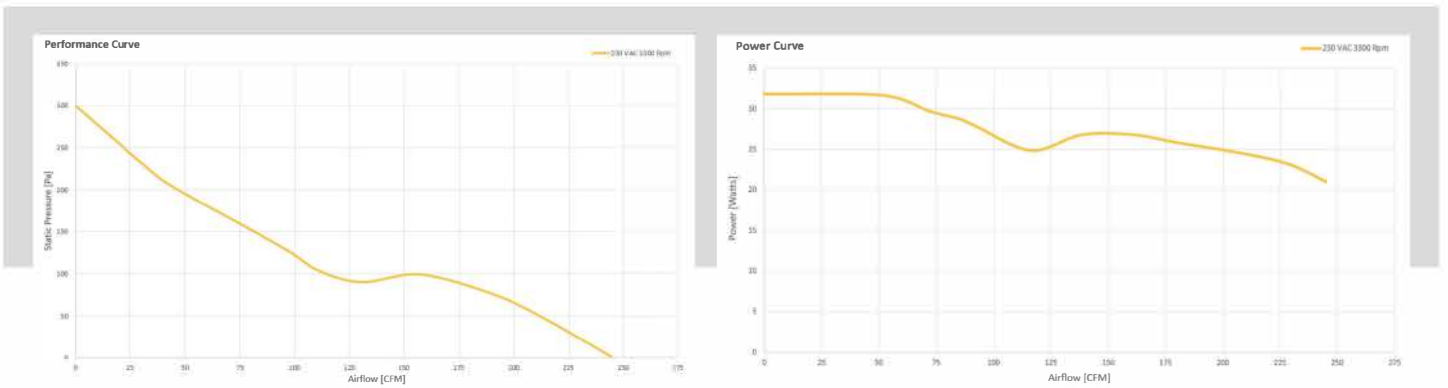

Curve 2

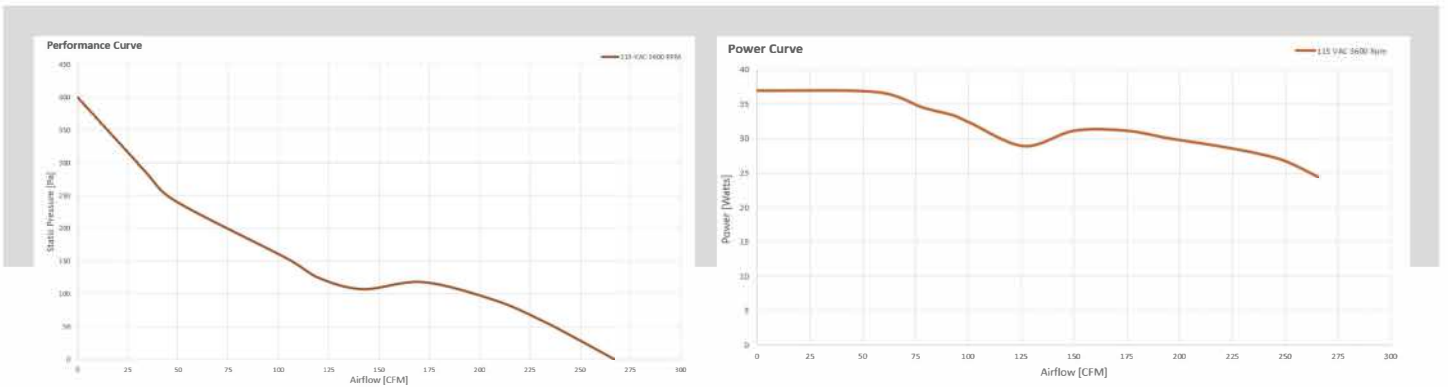

R&D Today For Tomorrow





www.anova.com.tr

Anova Head Office

ODTÜ MET Yerleşkesi,
Mustafa Kemal Mah. 2082 Cad.
No: 54/2/16
Çankaya/ANKARA/TÜRKİYE

Factory

Ankara Sanayi Odası
1. OSB, Babürşah
Cad. No:10
06935 Sincan/ANKARA/TÜRKİYE